

Front Cargo Box For Polaris Sportsman XP 850

ZP-YJ-030608-005



BEFORE YOU BEGIN

Read these instructions and check to be sure all parts and tools are accounted for. Please retain these installation instructions for future reference.

IMPORTANT

This FRONT CARGO BOX is exclusively designed for your vehicle. Please read the installation instructions thoroughly before beginning. Installation is easier if the vehicle is clean and free of debris.

INSTALLATION INSTRUCTIONS

Shift vehicle transmission into "PARK". Turn key to "OFF" position and remove from vehicle.

1. Release the two Lock & Ride anchors holding the front rack to the ATV.

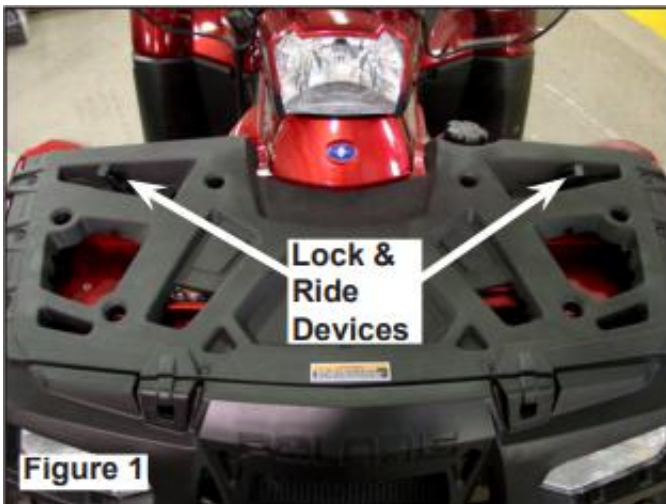

2. Lift up on the rear of the rack about 4 inches.



3. Slide the rack rearward. It should now be free from the front anchor points.



4. Remove the rack from the ATV and set aside.

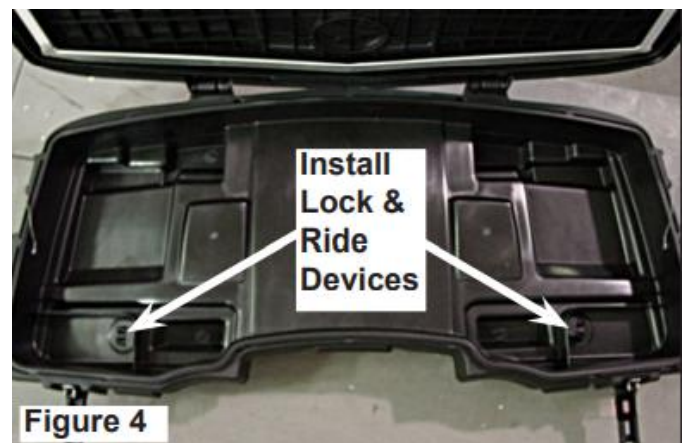

5. Assemble the two long Lock & Ride anchors (included with the front box assembly) through the base of the box per the instructions included with the Lock & Ride anchor kits. There is no self adjusting required for these Lock & Ride devices.

Front Cargo Box For Polaris Sportsman XP 850

ZP-YJ-030608-005

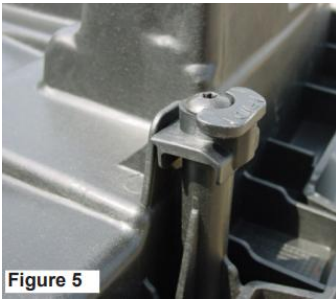
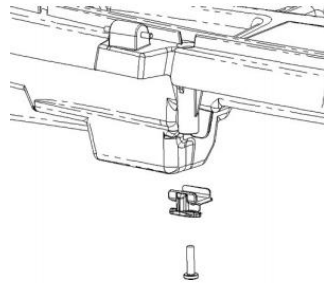

Figure 5



6. Install front rack guide. If you have a MY09 Sportsman XP or a MY10 Sportsman XP Touring or X2 you will need the metal four piece rack guide components (See Figure 6). For all other Sportsman XP vehicles, you will need the plastic rack guide (See Figure 5).

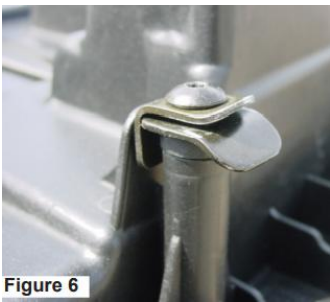
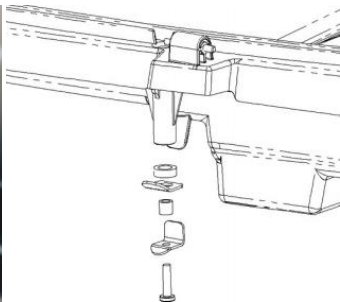

Figure 6



7. Install the box assembly in the opposite manner you removed the front rack by holding the rear of the box about 4 inches higher than the front. Position the front box latches in line with the rack support and slide the rack forward until the latches catch and you can not move any further forward.

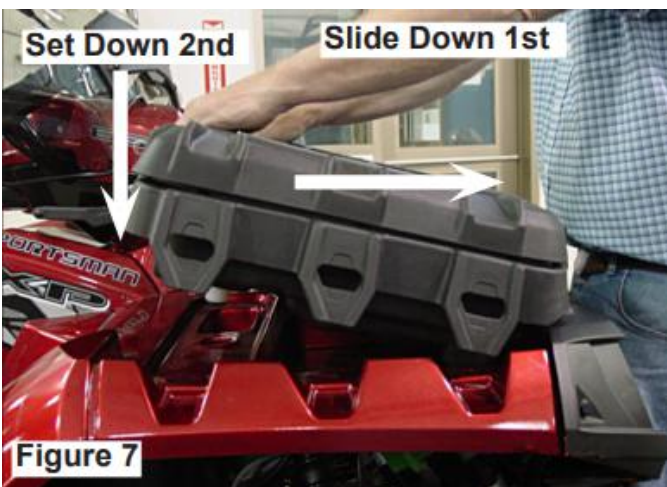

Figure 7

8. Lower the rear of the box and make sure it fits flat on the front of the vehicle.



Figure 8

9. Verify that the box is properly installed. NOTE: The front of the box must be secure in the front rack support, check this by trying to lift up on the front of the box. If the box comes loose, repeat the process starting from Step 6.

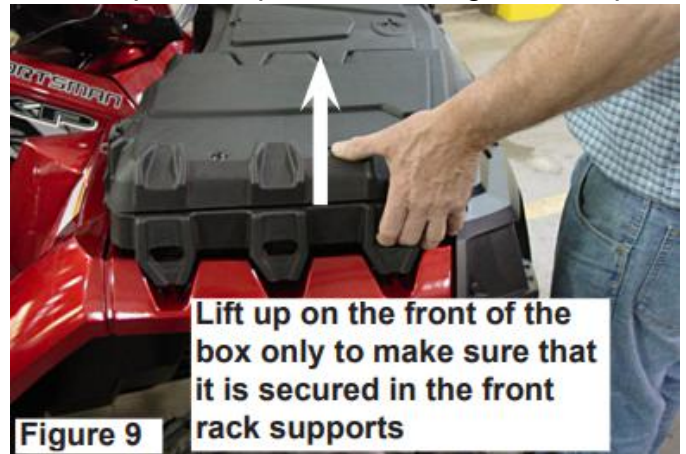

Figure 9

Lift up on the front of the box only to make sure that it is secured in the front rack supports

10. Lock the box to the vehicle by pushing down on the box and folding over the Lock & Ride latches.



Figure 10

Fold over the Lock & Ride handles to secure the front box into place

12-10-01-ax