

# CARGO BED RAILS FOR CAN AM COMMANDER

## BEFORE YOU BEGIN

Read these instructions and check to be sure all parts and tools are accounted for. Please retain these installation instructions for future reference.

## IMPORTANT

This CARGO BED RAILS KIT is exclusively designed for your vehicle. Please read the installation instructions thoroughly before beginning. Installation is easier if the vehicle is clean and free of debris.

**NOTE:** Shift vehicle transmission into "PARK". Turn key to "OFF" position and remove from vehicle.

## PARTS TO BE INSTALLED

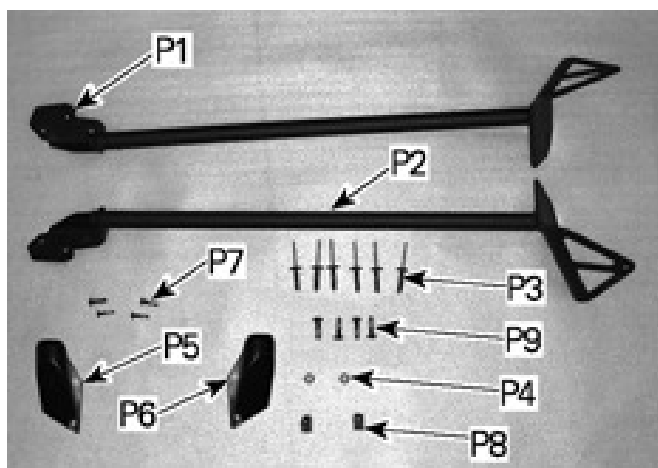

## INSTALLATION INSTRUCTIONS

1. Remove 2 retaining screws, cap nuts and washers from hand protector in front of cargo box. Keep cap nuts and washers for re-installation. Discard screws.

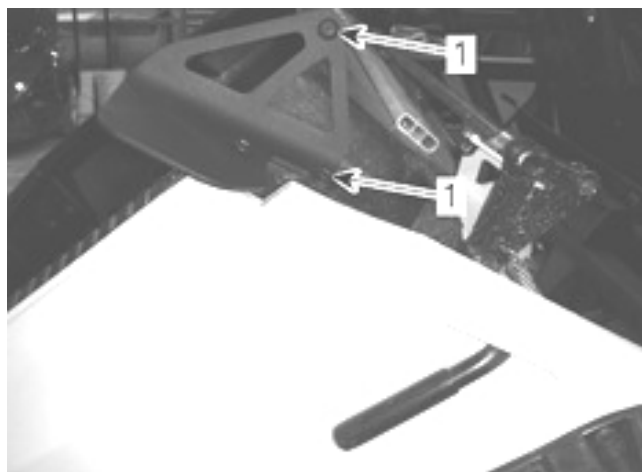

1. Hand protector retaining screws M6

2. Remove and keep retaining screws from hand protector in front of cargo box. Discard elastic nut.

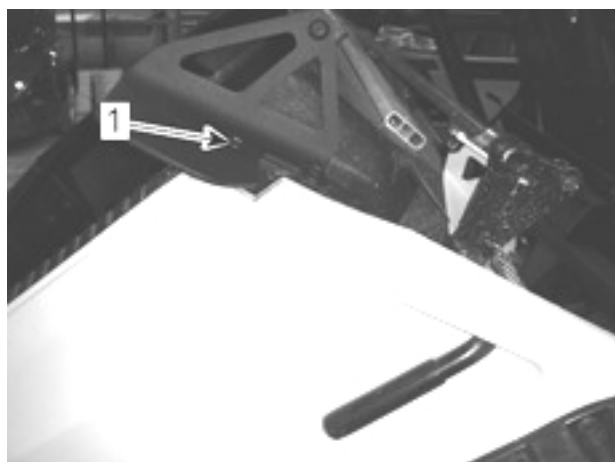

1. Hand protector retaining screw and elastic nut

3. Remove and discard retaining screw I cover located near tail gate.



1. Retaining screw for rail cover

4. Install template (the last page of this manual) over side wall of cargo box.

# CARGO BED RAILS FOR CAN AM COMMANDER

---

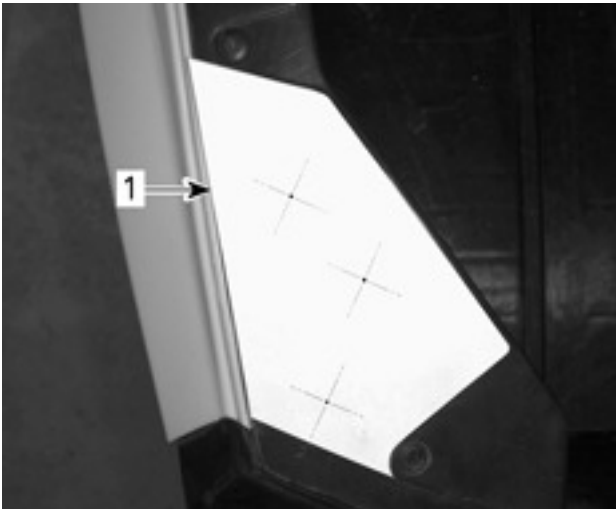

1. *Drilling template*

5. Use reference center points to punch hole locations.
6. Drill a 5.5 mm (7/32 in) hole at 3 locations.
7. Install rail in place and secure with 2 M6 retaining screws and cap nuts. Install M6 retaining screw and 1 new elastic nut located at hand guard. Do not torque yet.
8. Secure rail with 3 3/16 rivets at the rear end of cargo box.
9. Torque hand guard retaining screws and elastic nut.
10. Install U-nut onto rear section of rail.

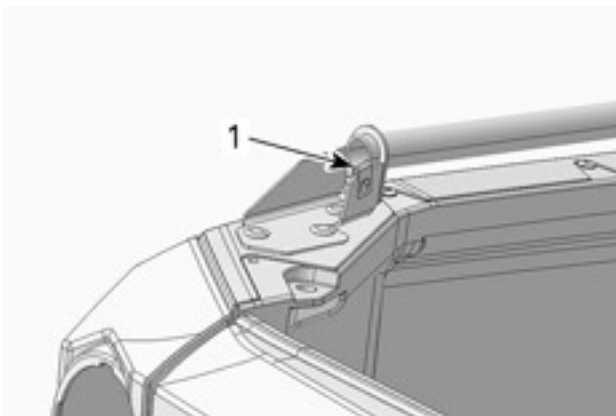

*U-NUT LOCATION TYPICAL*

11. Install rail cover and secure with new retaining screw onto U-nut.
12. Repeat steps 1 - 11 for other side.
13. Installation is complete.

# CARGO BED RAILS FOR CAN AM COMMANDER

