

# Front Bumper for Can Am Maverick X3

ZP-YJ-030606-001



## BEFORE YOU BEGIN

Read these instructions and check to be sure all parts and tools are accounted for. Please retain these installation instructions for future reference and parts ordering information.

## KIT CONTENTS

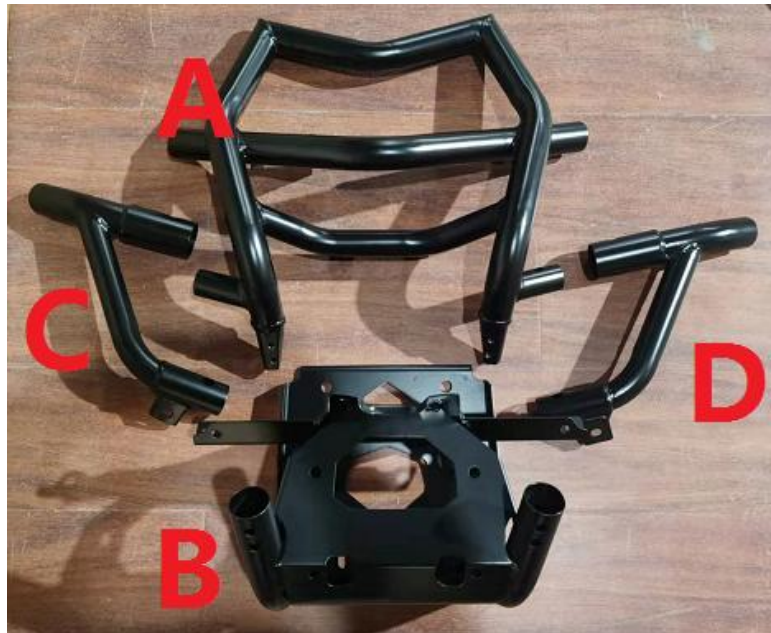

## IMPORTANT

This Front Bumper Kit is exclusively designed for your vehicle. Please read the installation instructions thoroughly before beginning. Installation is easier if the vehicle is clean and free of debris. For your safety, and to ensure a satisfactory installation, perform all installation steps correctly in the sequence shown.

## INSTALLATION INSTRUCTIONS

### 1. ACCESSORY INSTALLATION

1.1 Assemble part A and part B with four M8\*16 inner hexagon screws, two M8\*20 Outer hexagon screw and two M8 locknut.



1.2 Assemble part C and part D on part A with two M8\*40 and two M8\*50 inner hexagon screws.

# Front Bumper for Can Am Maverick X3

ZP-YJ-030606-001

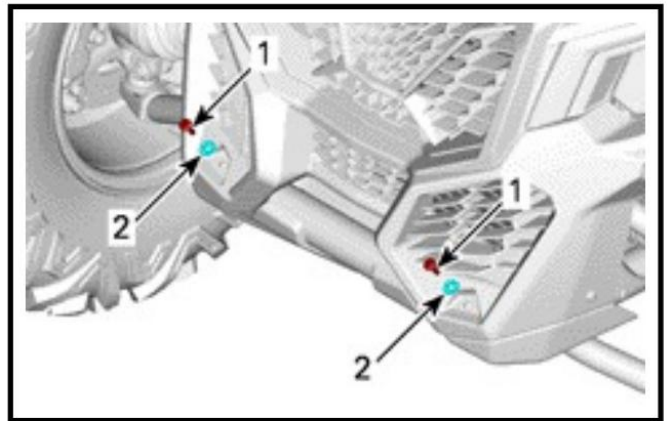

- 1. Screws
- 2. Washers

2.2 Remove and discard screws and nuts.

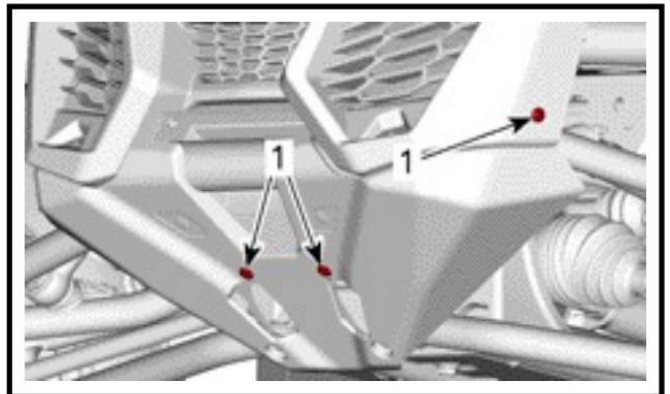

- 1. Screws

2.3 Remove and discard M12 nuts and M6 nut. Remove and keep M6 x 30 screws.



## 2. THE FRONT BUMPER INSTALLATION

2.1 Remove and discard screws and keep washers.

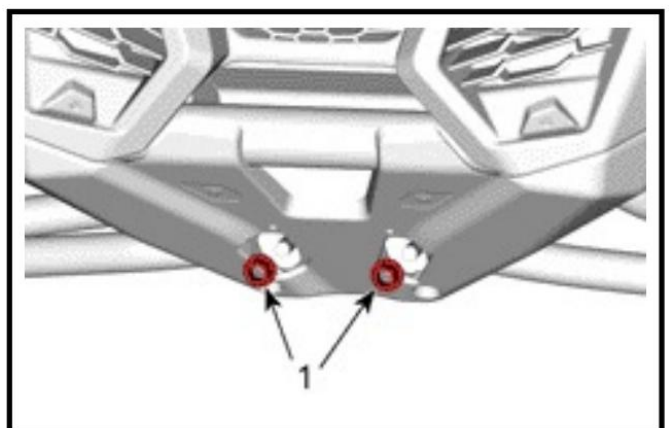

- 1. M12 nuts



# Front Bumper for Can Am Maverick X3

ZP-YJ-030606-001

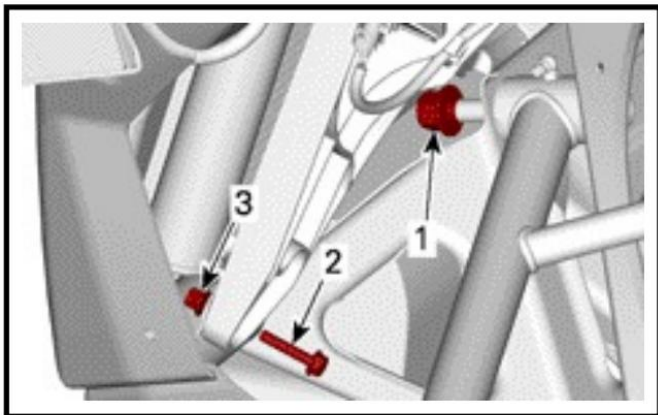

- 1. M12 nuts
- 2. M6 x 30 screws
- 3. M6 nuts

2.4 Lift with caution the radiator and remove front bumper.

Remove and discard radiator deflector.

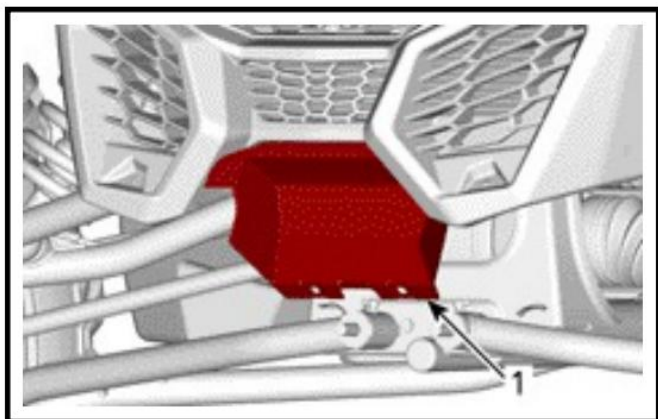

- 1. Radiator deflector

2.5 Remove and keep upper arm retaining screws.

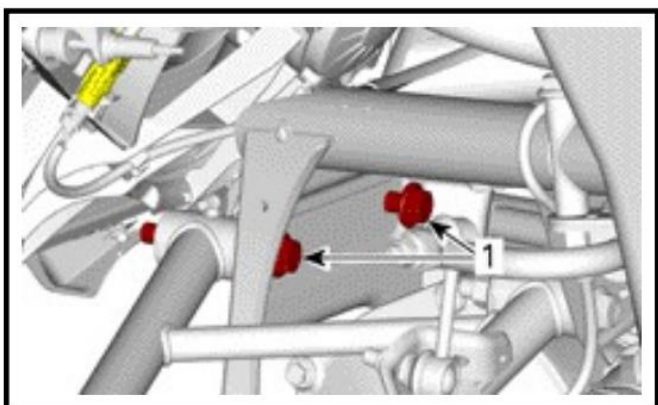

- 1. Upper arm retaining screws

2.6 Install stiffener plate and secure with upper arm retaining screws previously removed.

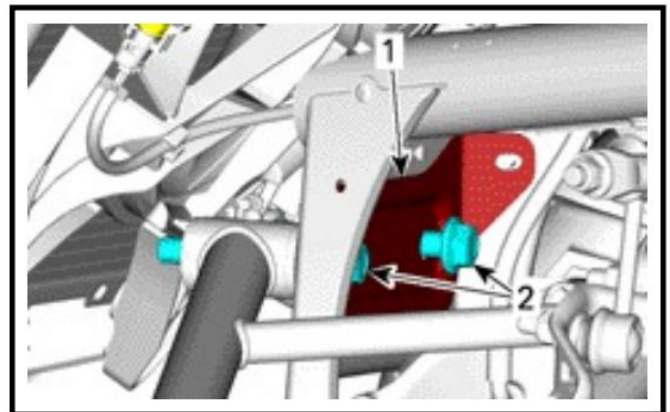

- 1. Stifner plate
- 2. Upper arm retaining screws

2.7 Install M6 x 16 hex flanged screws and M6 flange elastics nuts.

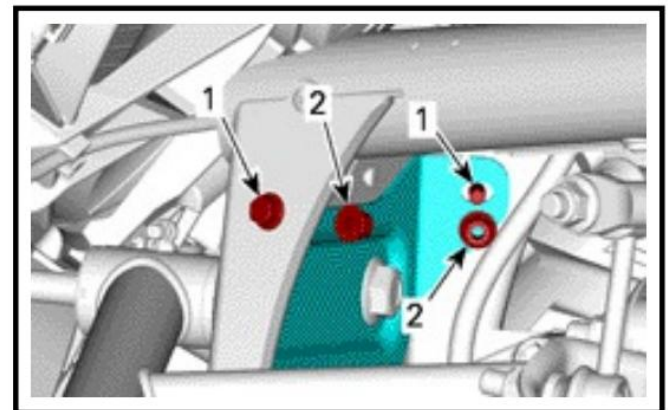

- 1. M6 x 16 hex flanged screws
- 2. M6 flange elastics nuts

2.8 Lift with caution the radiator and install front bumper.

Secure front bumper with M12 flanged elastic nut and flat washer.

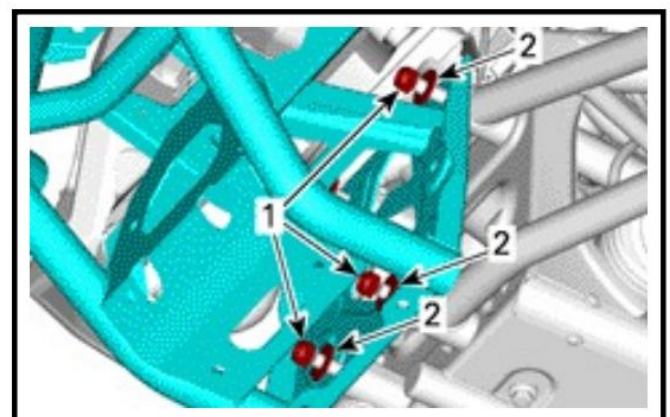

- 1. M12 flanged elastic nut
- 2. Flat washer

# Front Bumper for Can Am Maverick X3



ZP-YJ-030606-001

2.9 Torque M6 flange elastic nuts previously installed.

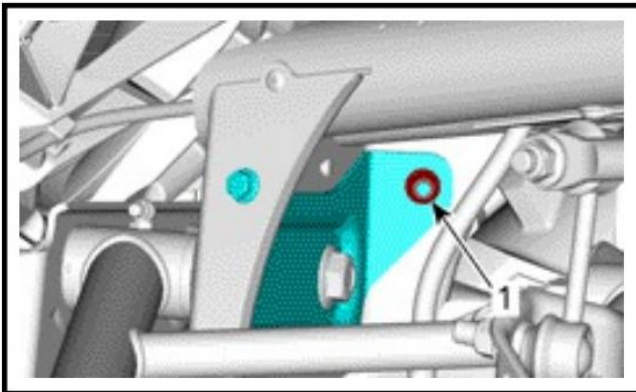

1. M6 flange elastic nuts

2.10 Install fascia support with a M6 panel nut. Secure fascia support with M6 x 16 hex flanged screw, M6 x 25 hex flanged screw and M6 panel nut.

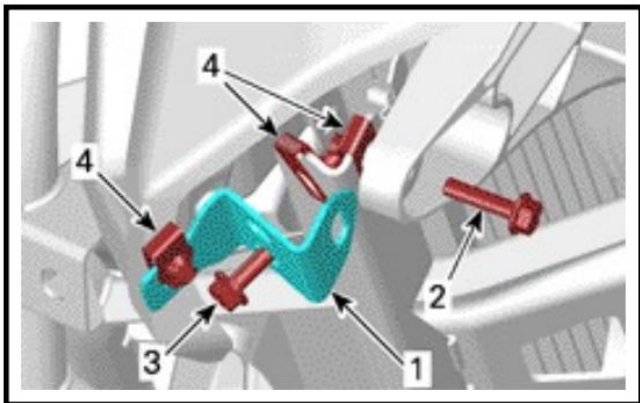

1. Fascia support
2. M6 x 25 hex flanged screw
3. M6 x 16 hex flanged screw
4. M6 panel nut

2.11 Install M6 x 20 torx screw with previously removed washer.

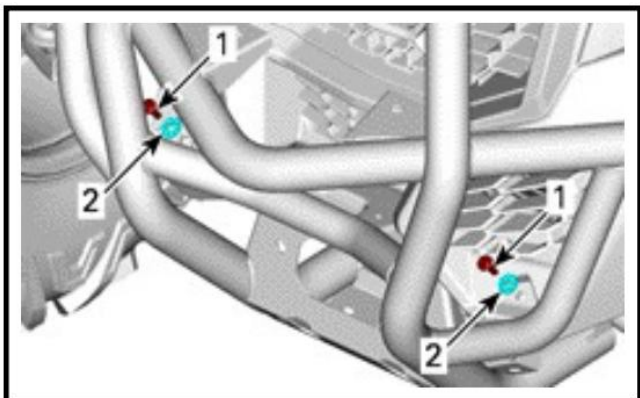

1. M6 x 20 torx screw

2.12 Install M6 x panel nut on front bumper.

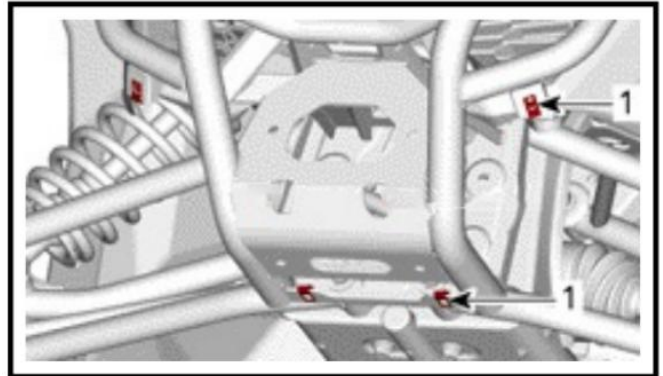

1. M6 x panel nut

2.13 Install front skid and secure with M6 x 20 torx screw.

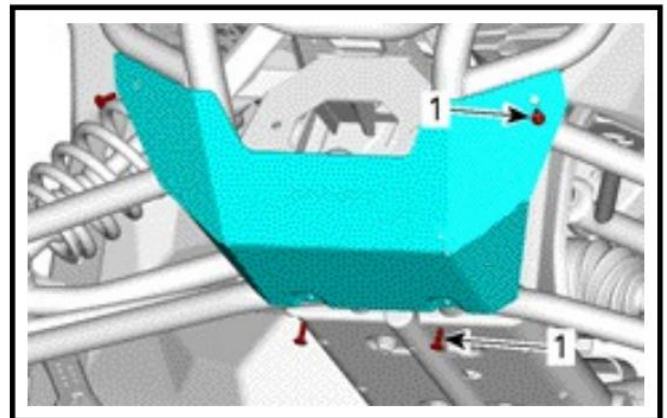

1. M6 x 20 torx screw

2.14 Install Cap on front bumper.

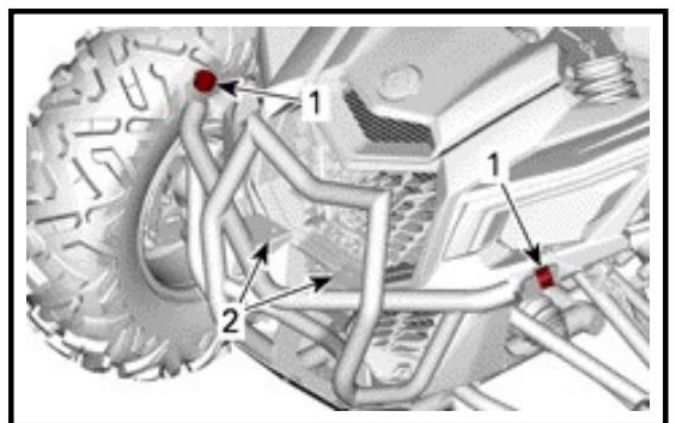

1. Cap
2. Light mount plate