

# Sports Fender Flares For Can-Am Defender



ZP-YJ-030610-010

## BEFORE YOU BEGIN



Read these instructions and check to be sure all parts and tools are accounted for. Please retain these installation instructions for future reference.

## IMPORTANT

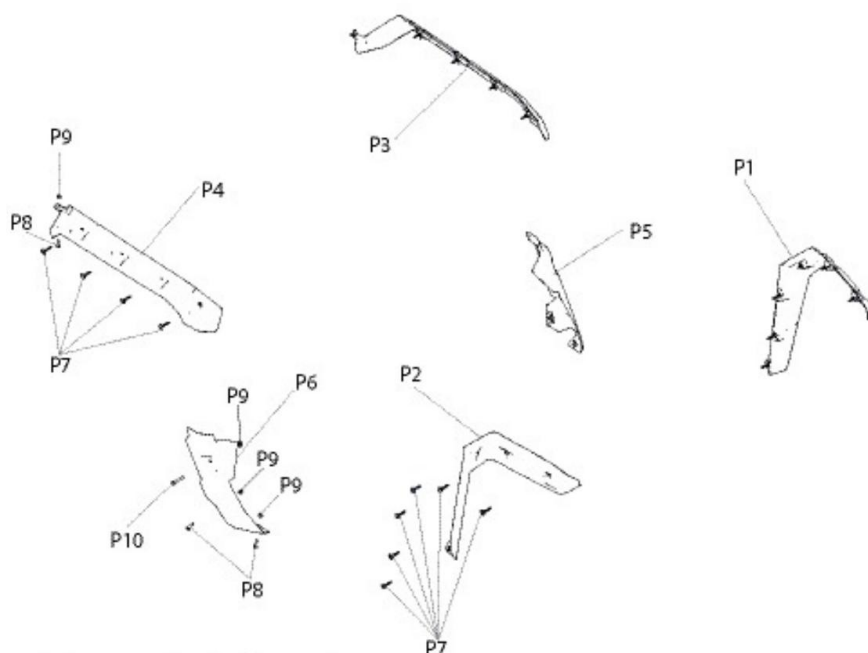
This SPORTS FENDER FLARES KIT is exclusively designed for your vehicle. Please read the installation instructions thoroughly before beginning. Installation is easier if the vehicle is clean and free of debris.



## REQUIRED TOOLS

Tools	Description	Use
T1	3 mm (1/8 in) drill 	Drill fender (guiding hole)
T2	7 mm (1/4 in) drill 	Drill body panels

## INSTALLATION INSTRUCTIONS

1. Shift vehicle transmission into "PARK". Turn key to "OFF" position and remove from vehicle.

**NOTE:** Procedure shown on one side only. Repeat on the other side.

### Front Flares

2. Carefully drill through fender (colored body panel) from inside with drill bit [T1] using molded hole as a template. Avoid any damage to the plastic cylinder post.

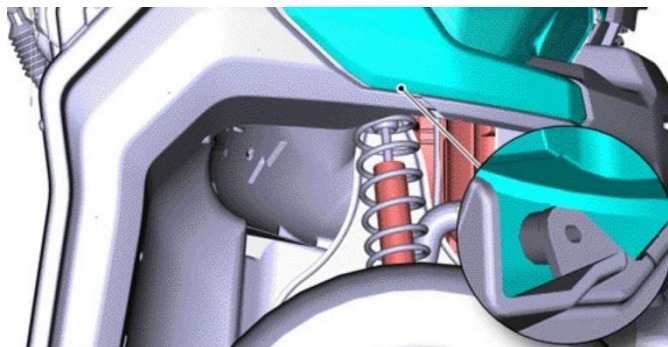

# Sports Fender Flares For Can-Am Defender

ZP-YJ-030610-010

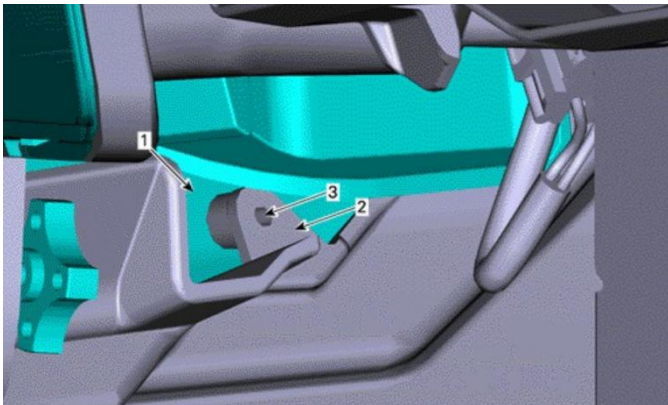

VIEW FROM INSIDE FENDER

1. Colored body panel
2. Fender trim
3. Drill here with [T1]
3. From outside, enlarge ONLY the fender (colored body panel) using [T2] (maximum 3 mm (1/8 in) deep).

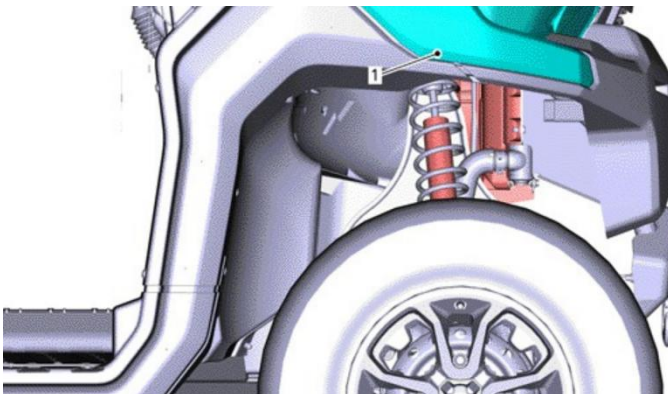

1. Drill here
4. Use the 5 dot marks on the front lateral and lower panels and the previously drilled hole to install the flare.

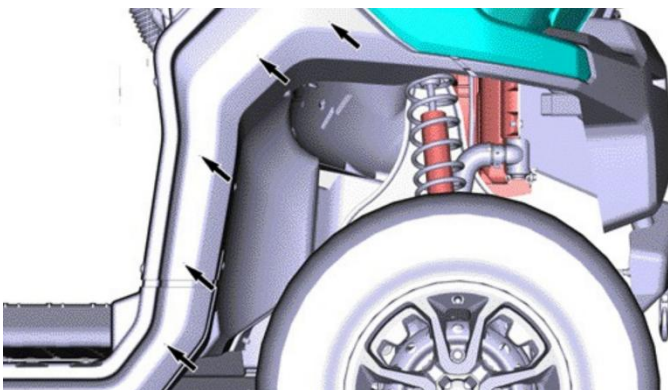

5. Approach flare [P2], then slightly thread all self tapping screws [P7].

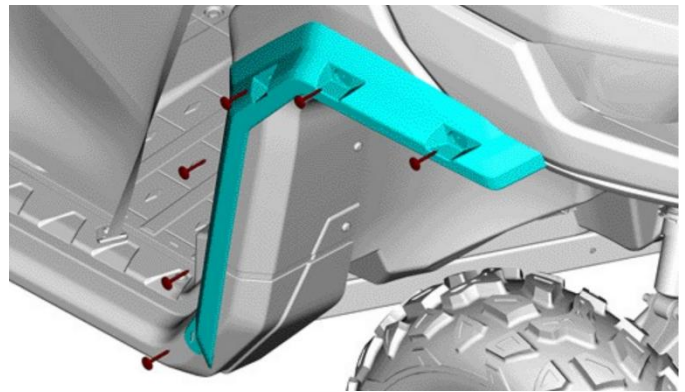

6. Position the flare to its best fit onto the lateral and lower panels. Carefully hand tighten screws.

## Center Flares

7. If vehicle is equipped with BODY SIDE PROTECTORS, trim flare as shown, using the molded line as a guide.

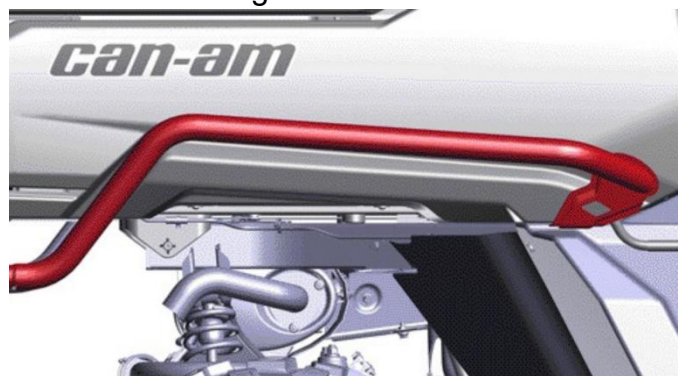

BODY SIDE PROTECTOR

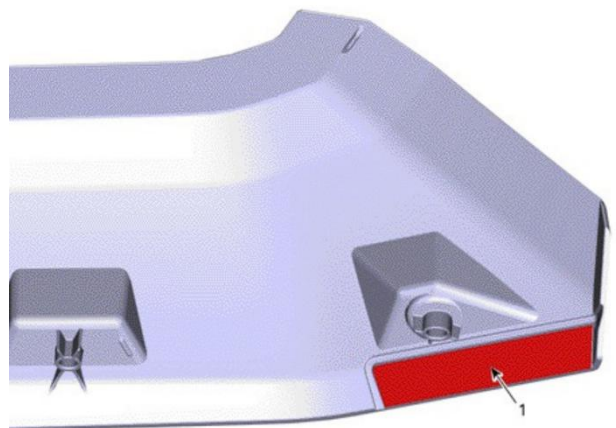

1. Remove this area
8. Use the 4 dot marks on the rear fender (black panel) to install the flare.

# Sports Fender Flares For Can-Am Defender

ZP-YJ-030610-010

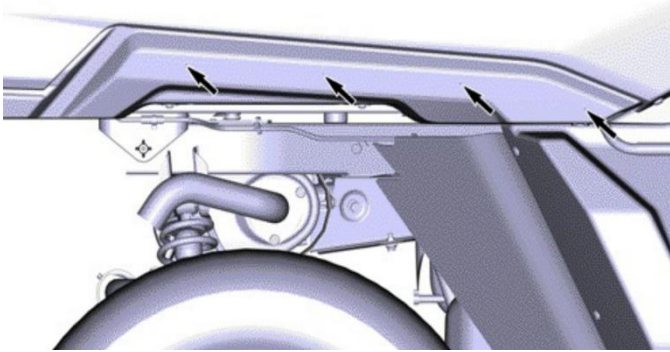

9. Approach flare [P6], then slightly thread all screws [P7].

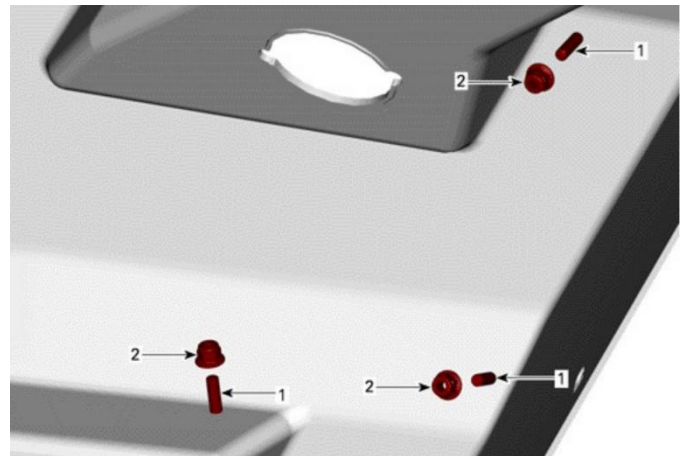

INSIDE FENDER PANEL - PARTS REMOVED FOR CLARITY

1. [P8] M6 X 25 screw

2. [P9] M6 flange nut

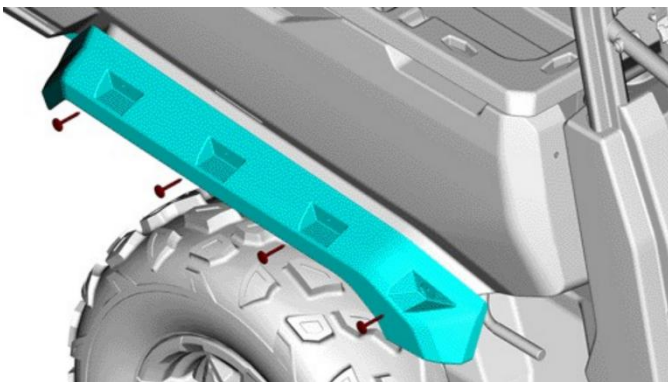

10. Position the flare to its best fit onto the rear panel. Carefully hand tighten screws.

## Cargo Flares

11. Position flare [P3] to its better fit and use it as a template.

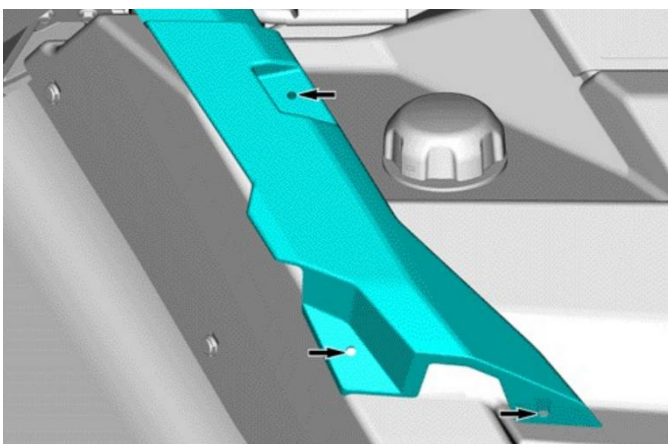

12. Drill mounting holes using [T2] (maximum 3 mm (1/8 in) deep). Install M6 X 25 screw [P8] from the outside and M6 flange nut [P9] from the inside.