

# Poly Roof for Kawasaki Mule 3000 4000 4010



ZP-YJ-031007-003

## BEFORE YOU BEGIN

Read these instructions and check to be sure all parts and tools are accounted for. Please retain these installation instructions for future reference.

## IMPORTANT

This POLY ROOF is exclusively designed for your vehicle. Please read the installation instructions thoroughly before beginning. Installation is easier if the vehicle is clean and free of debris.

## INSTALLATION INSTRUCTIONS

1. Shift vehicle transmission into "PARK". Turn key to "OFF" position and remove from vehicle.
2. Paste the seals on the edge of one half roof, just as the following images show.



3. Use the screws in the mount hardware package to fix the two half roofs together to form a complete roof.

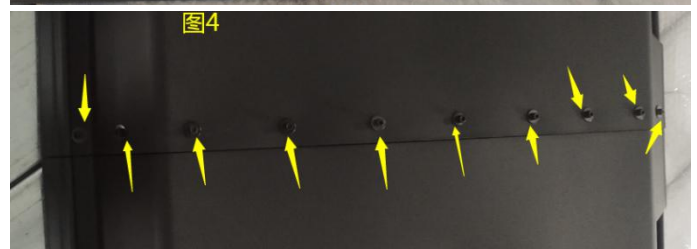
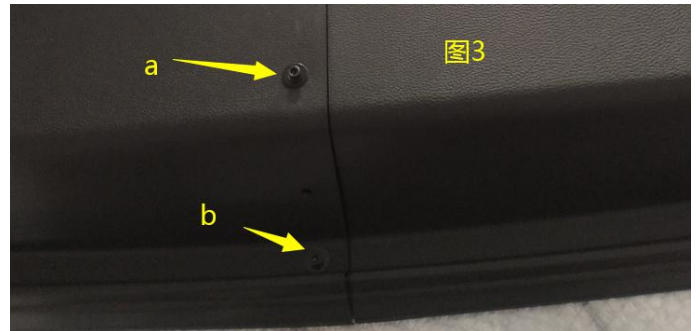
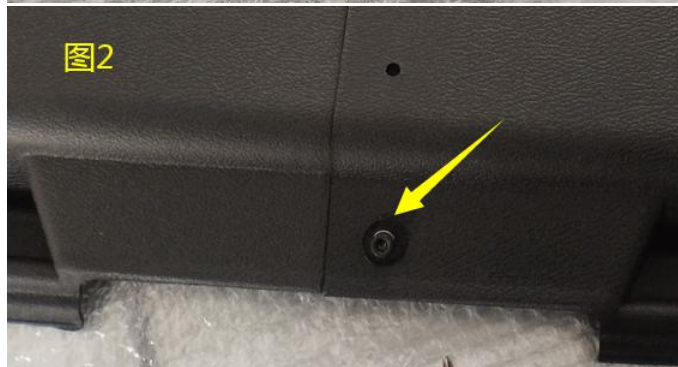
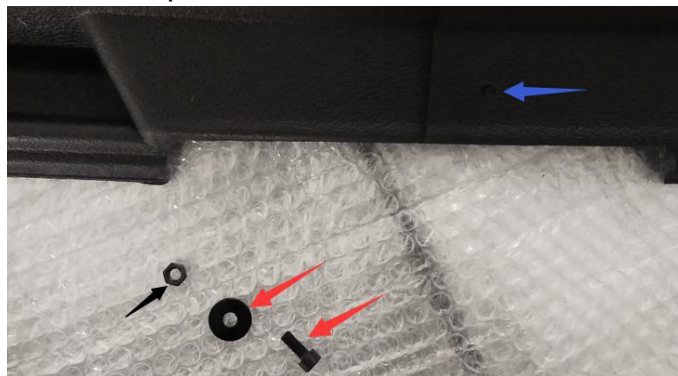

4. If a windshield is to be installed, install it first.

5. Place the hard top on the Mule Cab frame bars. Position it so that the molded-in ribs match the front/rear tubes, and so that the position is as far to the rear as possible without touching the front corners of the cab frame tubes. If the windshield is installed, be sure that the top matches position with the windshield overlap onto the cab frame.

6. Install the attachment brackets over the cab frame tubes from the bottom side, and secure at each end with the supplied stainless steel screws. Insert the screws from the top. Be careful to avoid over-tightening the screws. (A small amount of RTV silicone in a matching or clear color can be applied under the head of

# Poly Roof for Kawasaki Mule 3000 4000 4010



ZP-YJ-031007-003

the screw to promote water-proofing).

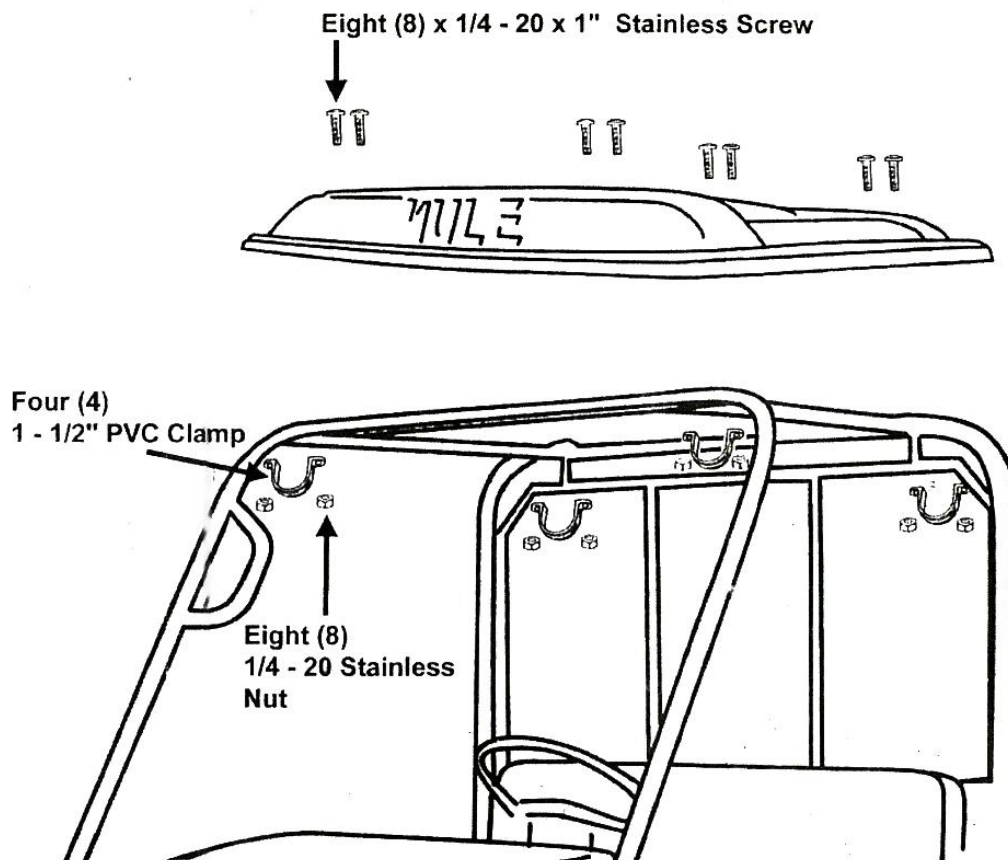

## **NOTICE:**

Top must be removed for transport on open trailer or truck at speeds higher than normal vehicle speed.