

Front Bumper Kit for Polaris RZR PRO XP

ZP-YJ-030506-020



BEFORE YOU BEGIN

Read these instructions and check to be sure all parts and tools are accounted for. Please retain these installation instructions for future reference.

IMPORTANT

The Front Bumper Kit is exclusively designed for your vehicle. Please read the installation instructions thoroughly before beginning. Installation is easier if the vehicle is clean and free of debris. For your safety, and to ensure a satisfactory installation, perform all installation steps correctly in the sequence shown.

INSTRUCTIONS

ASSEMBLY



1. Assemble parts 1, 2 and 3 together with two M6 * 50 hexagon socket screws, two M8 locknuts.



2. Assemble parts 4, 5 and upper frame tubes together with four M8*55 hexagon socket screws and four M8 locknuts.



KIT CONTENTS

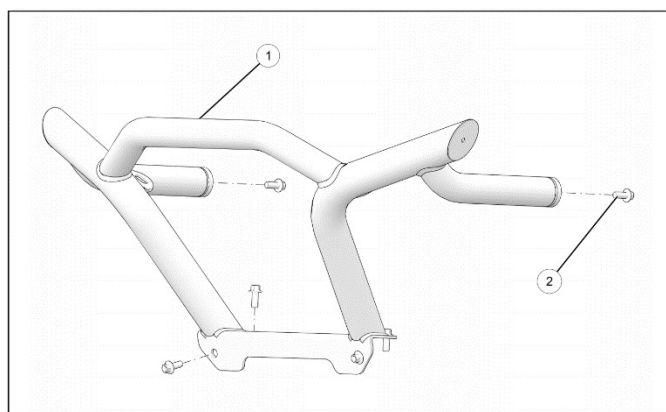

TOOLS REQUIRED

- Safety Glasses
- Socket Set, Metric
- Torque Wrench

INSTALLATION INSTRUCTIONS

VEHICLE PREPARATION

GENERAL

1. Shift vehicle transmission into PARK. Turn ignition switch to OFF position and remove key.

GRILLE REMOVAL

1. Pull down on two tabs, located on top-edge of grille.

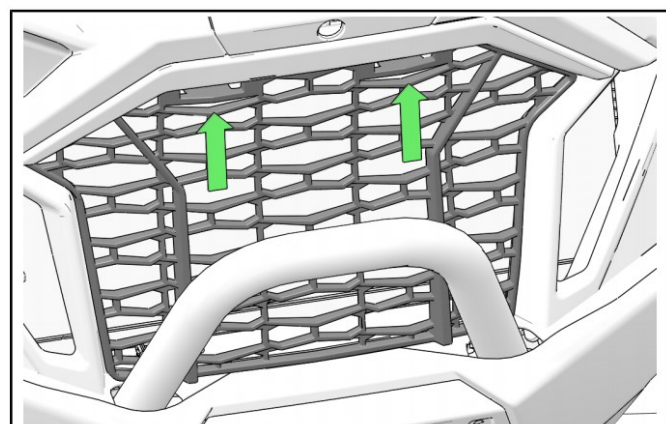

Front Bumper Kit for Polaris RZR PRO XP

ZP-YJ-030506-020



2. Tip grille forward and pull out until bottom tabs are clear of front fascia and bull bumper.

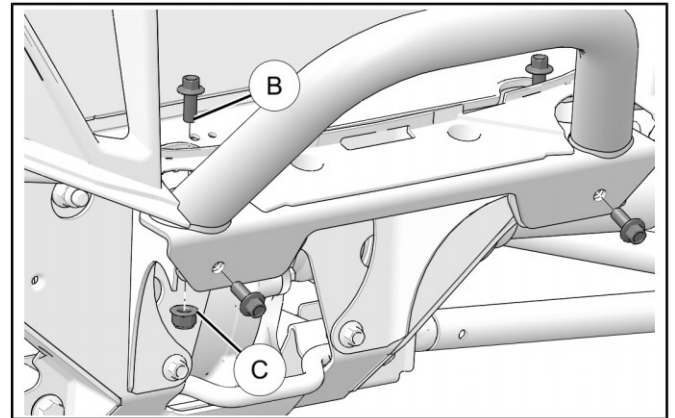
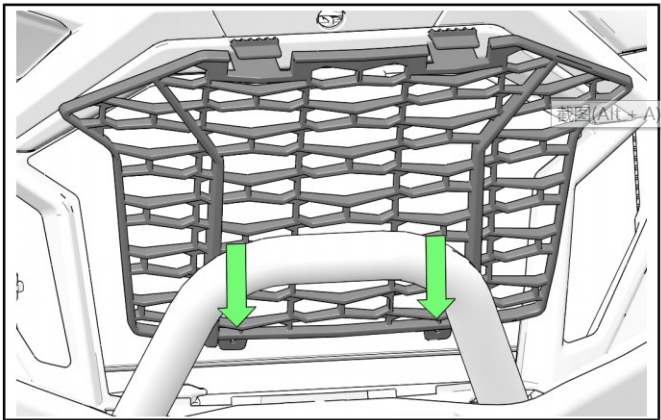

BUMPER FASCIA REMOVAL

1. Remove and retain one screw A and one screw B from each side of bumper fascia.

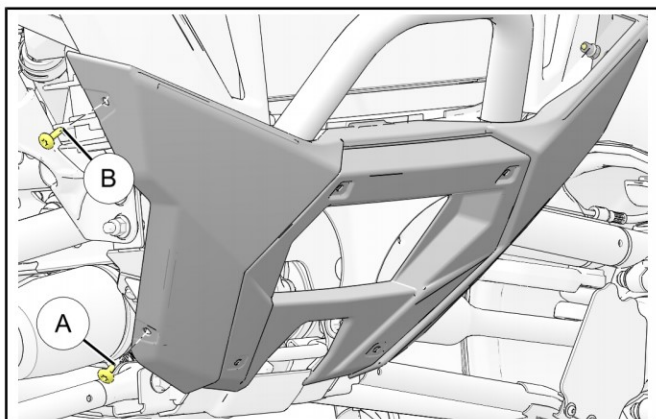

BULL BUMPER REMOVAL

1. Remove and retain two push-pin rivets A, holding front fascia to bull bumper.

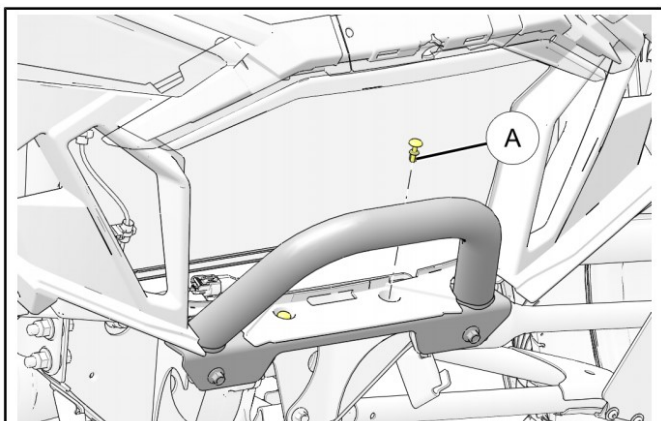

2. Remove and discard four screws B and retain four nuts C connecting bull bumper to bumper brackets.

ACCESSORY INSTALLATION

1. Align arms of bumper 1 into front fascia openings, below headlights.

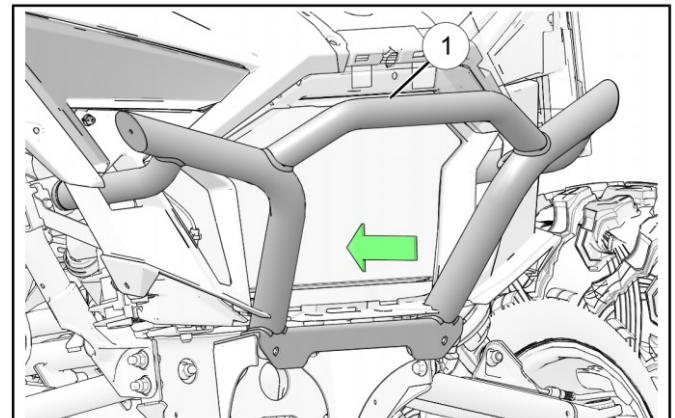

2. Install bumper 1 onto two bumper brackets with four bolts 2 and four retained nuts A. Counter-hold nuts A while torquing bolts 2.

NOTE

Nuts (A) for front-facing bolts (2) are located behind bumper (1).

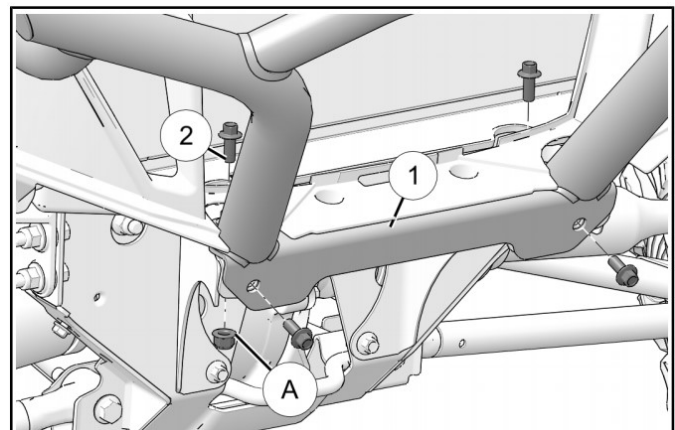

3. Install each arm of bumper 1 with one bolt 2.

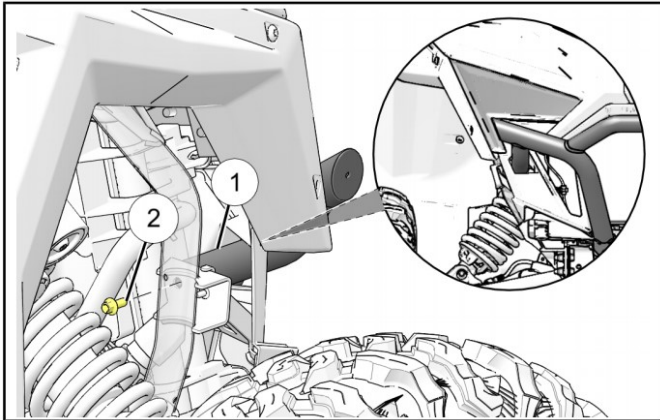

VEHICLE REASSEMBLY SECURING FRONT FASCIA

1. Secure front fascia to bumper 1 with two retained push pin rivets A.

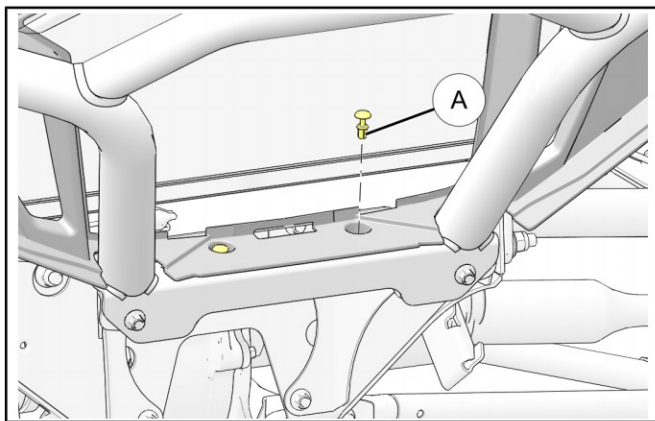

BUMPER FASCIA REINSTALLATION

1. Reinstall bumper fascia with two screws A and two screws B.

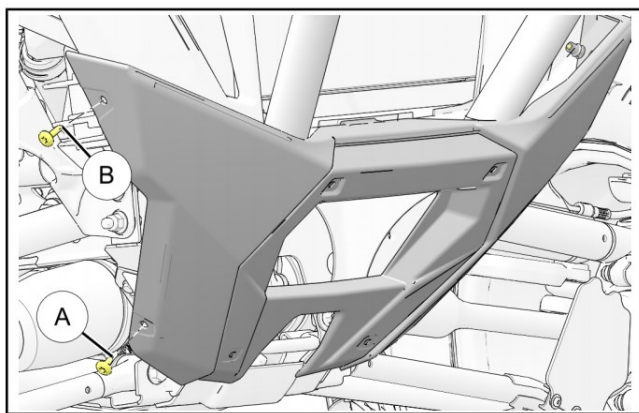

GRILLE INSTALLATION

1. Tip bottom grille tabs into front fascia.

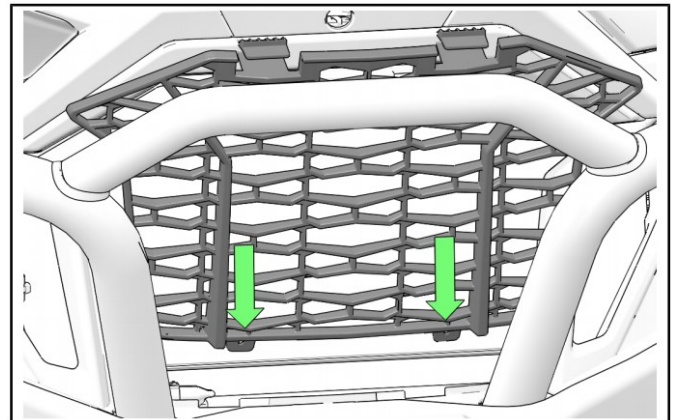

2. Push top of grille into front fascia until grille snaps into place.

