

COMBINED ROOF KIT FOR POLARIS RANGER XP 1000

BEFORE YOU BEGIN

Read these instructions and check to be sure all parts and tools are accounted for. Please retain these installation instructions for future reference.

IMPORTANT

This COMBINED ROOF KIT is exclusively designed for your vehicle. Please read the installation instructions thoroughly before beginning. Installation is easier if the vehicle is clean and free of debris.

INSTALLATION INSTRUCTIONS

1. Shift vehicle transmission into "PARK". Turn key to "OFF" position and remove from vehicle.
2. Cut the sealing strip of appropriate length and paste it on the front half roof along the red line as shown in the following images.



3. Align the 2 half roofs, fix them together using M6x18 self tapped screws, forming a complete roof.

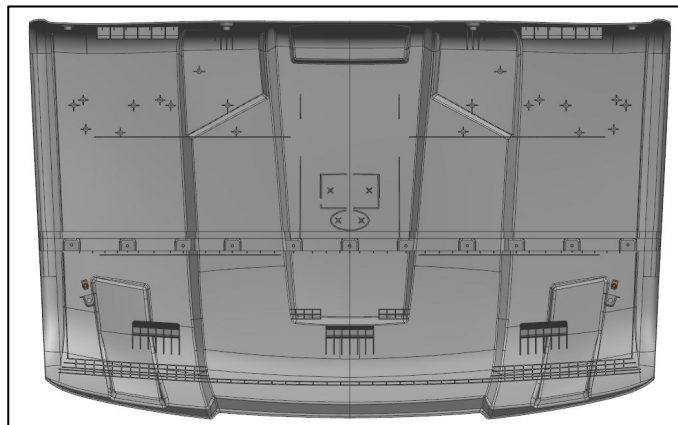
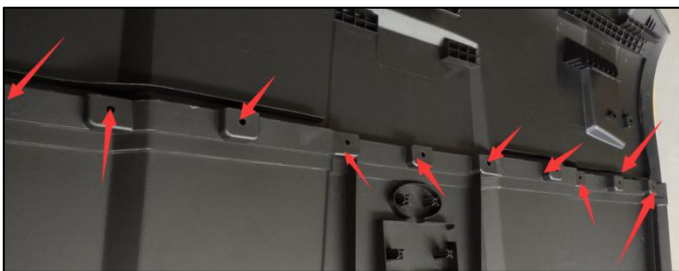

4. Install two clip nuts (3) to standoffs at front of roof panel (1). Ensure proper orientation: Threaded portion of clip nut is located INSIDE standoff.

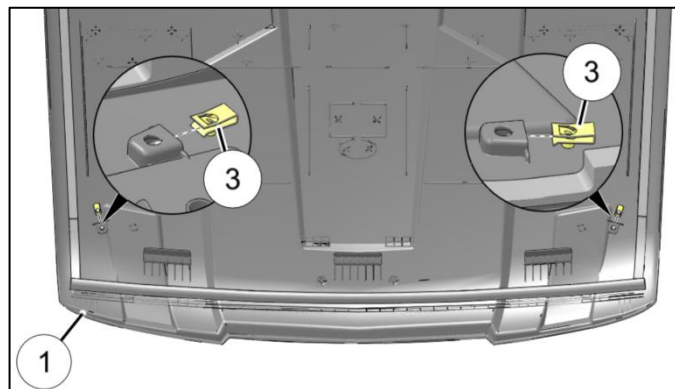

5. Clean upper surface of ROPS visor.
6. Lay roof panel on top of ROPS, inserting three hooks (C) through openings in ROPS visor.

COMBINED ROOF KIT FOR POLARIS RANGER XP 1000

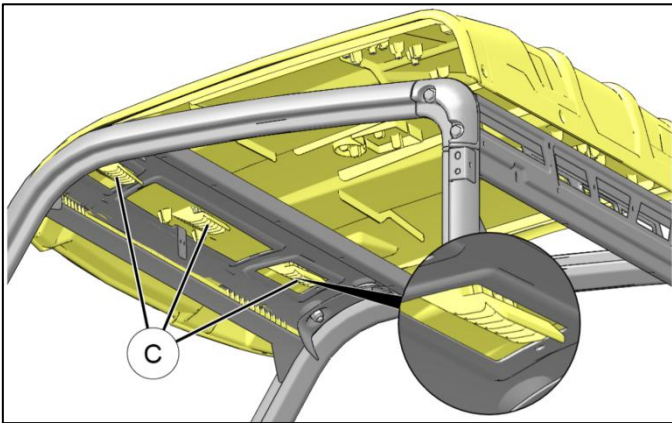
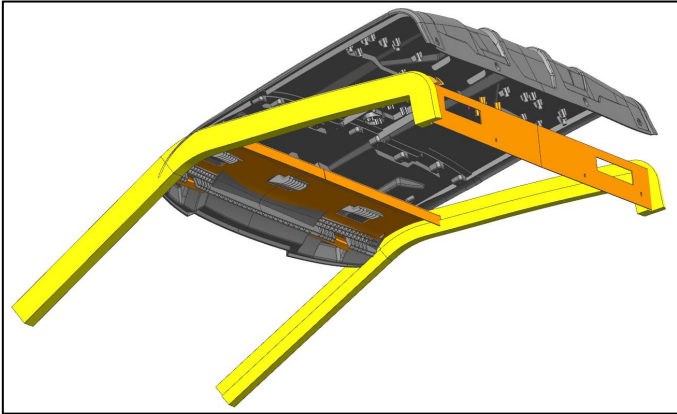

7. Slide roof panel rearward until hooks (C) lock into ROPS visor, then press rear of roof panel down until two tabs (D) snap into B-pillar cross-member.

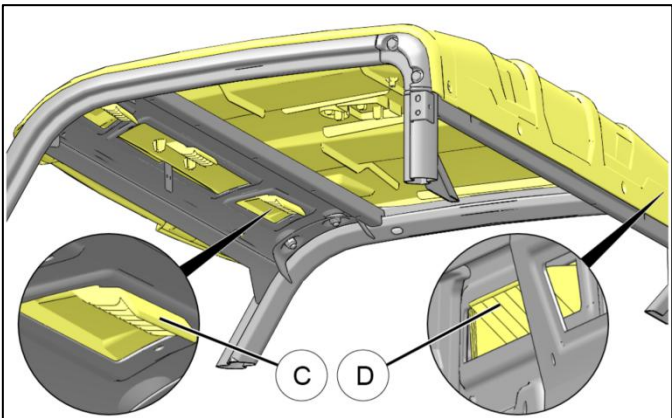

8. Secure front right corner of roof panel to ROPS using screw (4). Repeat for front left corner.

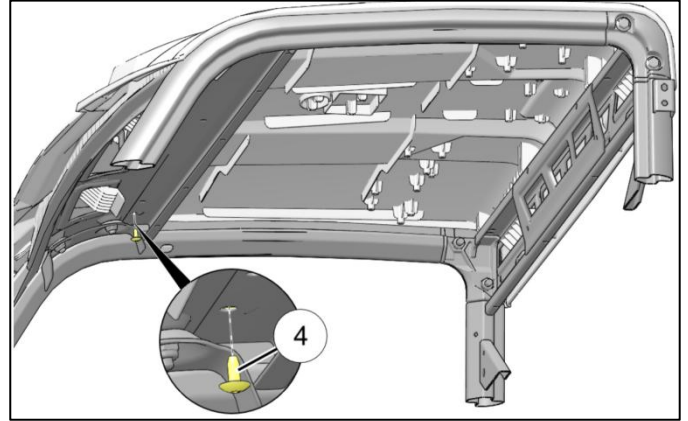

9. Secure rear edge of roof panel to ROPS using four screws (2).

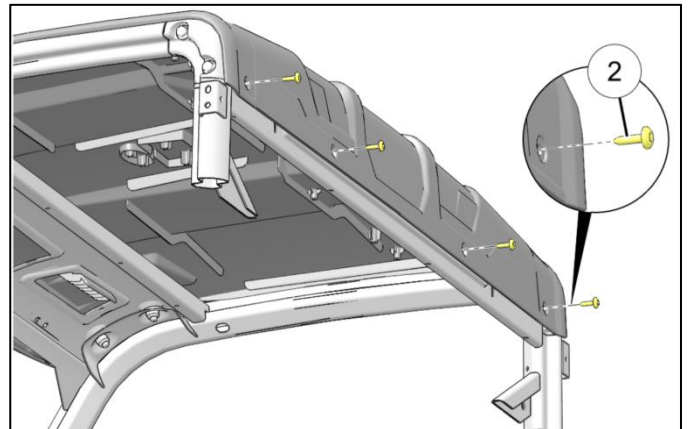

10. Torque screws (2) and (4) to specification.