

LinQ Base Installation Kit for SEA-DOO GTI, GTS, GTR-X, RXP and GTR



ZP-YJ-030603-104

BEFORE YOU BEGIN

Read these instructions and check to be sure all parts and tools are accounted for. Please retain these installation instructions for future reference.

IMPORTANT

The LinQ Base Installation Kit are exclusively designed for your boat. Please read the installation instructions thoroughly before beginning. Installation is easier if the vehicle is clean and free of debris. For your safety, and to ensure a satisfactory installation, perform all installation steps correctly in the sequence shown.

REQUIRED TOOLS

| Required Tool | | Use |
|---------------|----------------------------|----------------------------|
| T1 | Drill bit 5.5 mm (7/32 in) | To drill holes in the body |

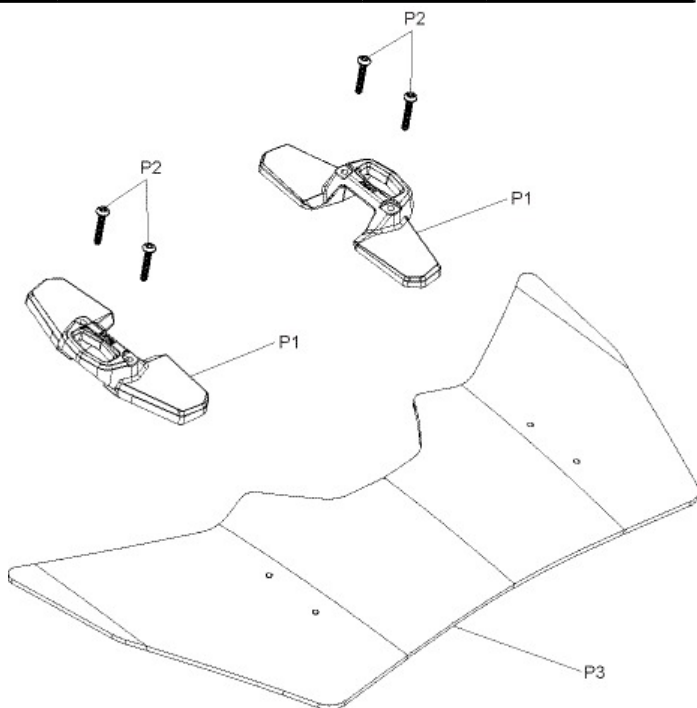

INSTRUCTIONS

1. Install Anti Slip Mat [P3]:

1.1 Remove already fixed swim platform mat (for GTR/RXP, try to keep the mat in one piece since it is needed as a template to cut the supplied mat).
1.2 Clean the installation area with isopropyl

alcohol.

NOTE: For GTR and RXP only, trim the anti slip mat [P3] using the removed mat.

1.3 Before peeling any protective backing, position mat on the surface to obtain proper alignment. Find the central axis of the vehicle (line 3), using the dimension D from points 1 and 2.

1.4 Use the dimensions A, B and C as references to mark the points 4, 5, 6 and 7.

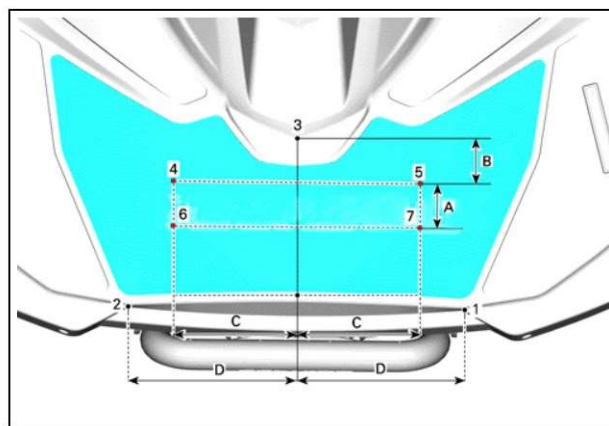

A. 70 mm (2-3/4 in)

B. 72 mm (2-27/32 in)

C. 194 mm (7-5/8 in)

D. 268 mm (10-9/16 in)

1.5 Peel protective backing off and affix mat to the platform. Apply pressure on carpet surface to ensure all surface is glued properly.

2. Use the previously installed mat and drill four 5.5 mm (7/32 in) holes at marked locations. (4,5,6,7)

NOTICE Be careful to not touch the exhaust

LinQ Base Installation Kit for SEA-DOO GTI, GTS, GTR-X, RXP and GTR



ZP-YJ-030603-104

system with the drill bit. Do not drill deeper than 15 mm (9/16 in).

| Drill size | |
|------------|------------------|
| T1 | 5.5 mm (7/32 in) |

3. Install the two LinQ plate [P1] on the carpet with four M6.81x45 Plastite Torx screw [P2].

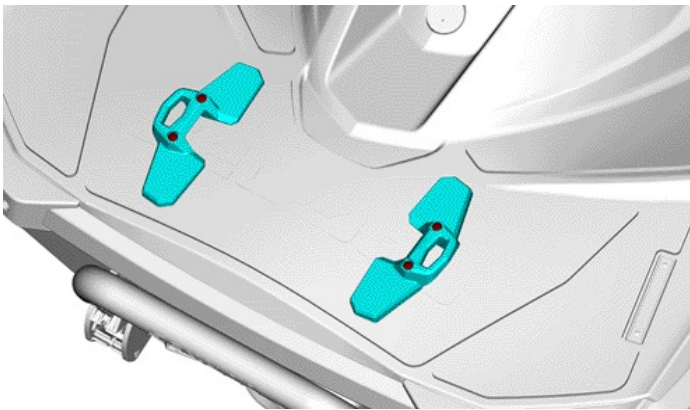

| Tightening torque | |
|-----------------------------------|------------------------------|
| M6.81x45 Plastite Torx screw [P2] | 7 to 8 N•m (62 to 71 lbf•in) |

4. By installing an accessory like a LinQ cooler or a LinQ fuel caddy, you can verify that the cargo bases are correctly installed.

