

# Snap-In Fenders Installation Kit for Sea-Doo GTI

ZP-YJ-030603-116



## BEFORE YOU BEGIN



Read these instructions and check to be sure all parts and tools are accounted for. Please retain these installation instructions for future reference.

## IMPORTANT

This fender Installation kit is exclusively designed for your boat. Please read the installation instructions thoroughly before beginning. Installation is easier if the vehicle is clean and free of debris.

**Note:** Shift watercraft transmission into "PARK". Turn key to "OFF" position and remove from watercraft.

## REQUIRED TOOLS

Required Tool		Use
T1	Center drill 	To drill side bumper
T2	Drill bit 5.5 mm (7/32 in) 	To drill side bumper

## PARTS TO BE INSTALLED

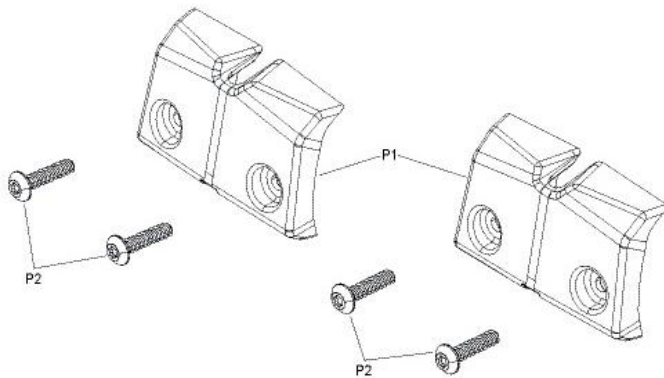

## INSTALLATION INSTRUCTIONS

### Preparation

1. Position mounting plates [P1] on side bumper as shown.
  - 1.1 Look under bumper to locate the rib at this position.

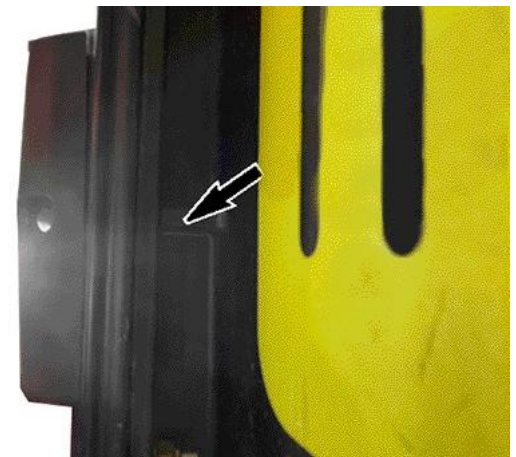

**Notice:** While looking under the bumper, make sure there are no screws at this position.

- 1.2 Center the mounting plates [P1] around the rib.

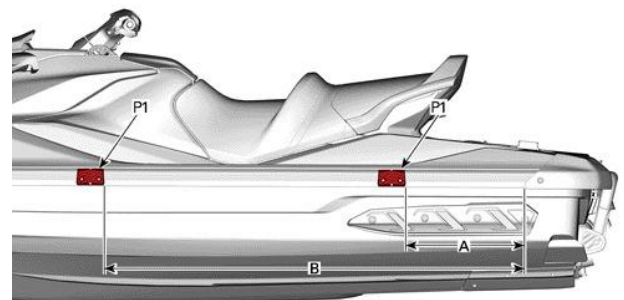

A. 460 mm (18 in)

B. WITH sound system 1 575 mm (62 in), WITHOUT sound system 1 625 mm (64 in)

2. Mark the location of the (4) holes using mounting plates [P1] as template.

- 2.1 Push firmly on the top of the bracket when you mark the bolt location.

3. Remove mounting plates [P1].

# Snap-In Fenders Installation Kit for Sea-Doo GTI

ZP-YJ-030603-116



4. Use center drill [T1] on marked locations.
5. Drill four (4) 5.5 mm (7/32 in) holes into holes recently made using drill bit 5.5 mm (7/32 in)[T2].

**NOTE:** Hold the center drill and the drill horizontally.

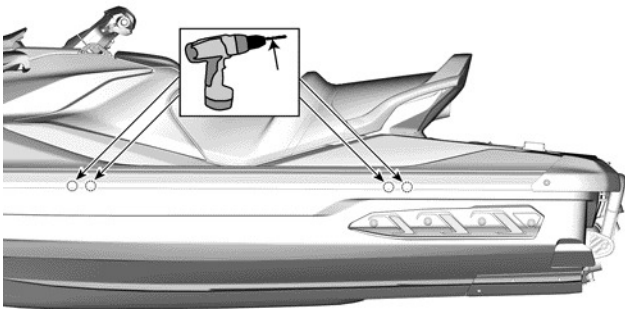

## Part Installation

Install the mounting plates [P1] using two (2) M6.81 X 30 Torx screws [P2] each. Tighten to specification.

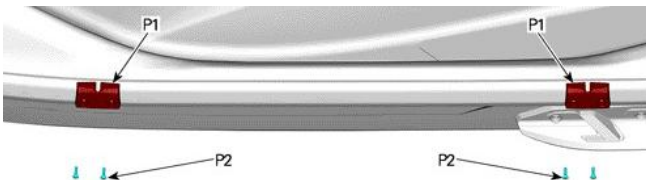

Tightening Torque	
M6.81 X 30 Torx screw [P2]	5 ± 0.5 N•m (44 ± 4 lbf•in)