

FENDER FLARES KIT FOR CAN-AM RYKER

ZP-YJ-030610-012



BEFORE YOU BEGIN

Read these instructions and check to be sure all parts and tools are accounted for. Please retain these installation instructions for future reference.

IMPORTANT

Your FENDER FLARES KIT is exclusively designed for your vehicle. Please read the installation instructions thoroughly before beginning. Installation is easier if the vehicle is clean and free of debris.

INSTALLATION INSTRUCTIONS

NOTE: Shift vehicle transmission into "PARK". Turn key to "OFF" position and remove from vehicle.

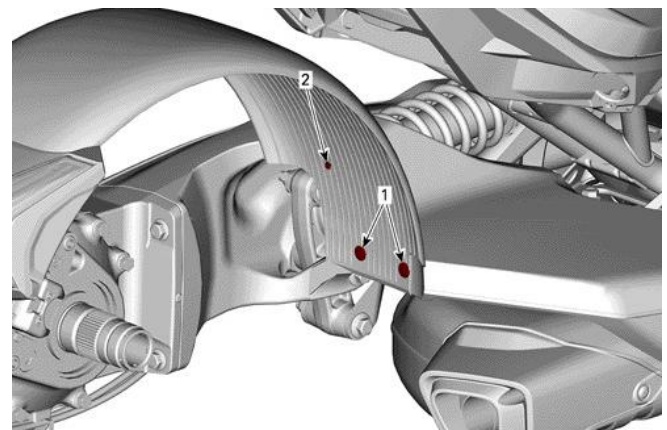
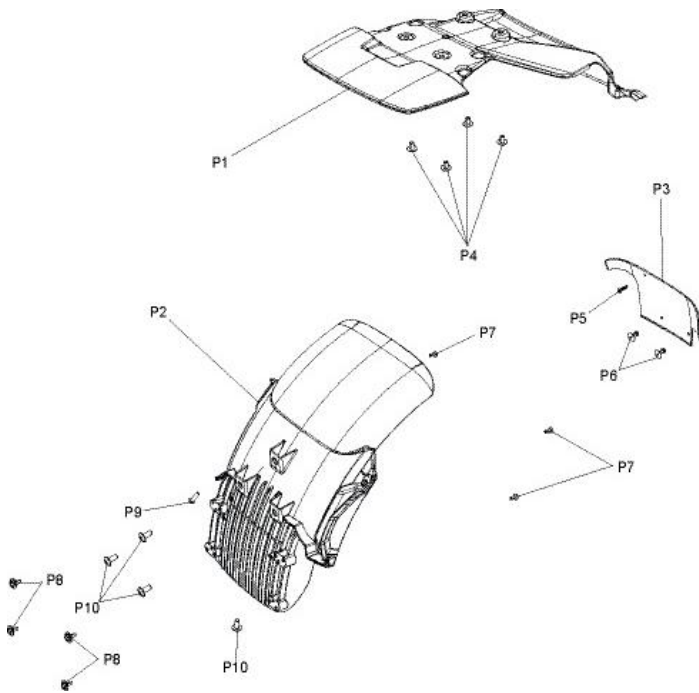

1. Rivets
2. Screw

3. Remove and discard the shown screws retaining the tail lights.

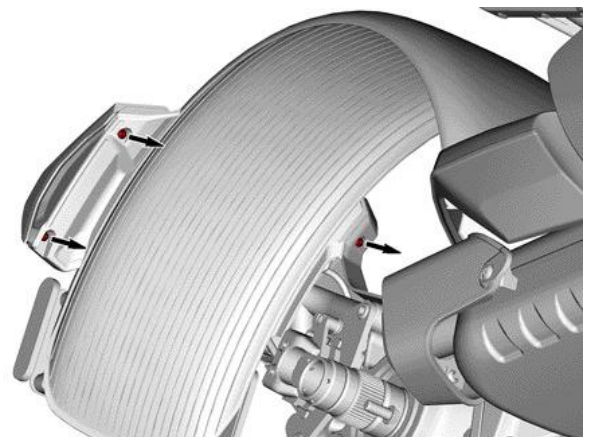

4. Remove and discard the four (4) screws retaining the reflectors.

Vehicle Preparation

NOTE: Make sure that the MAX Mount Kit (P/N 219400800) is installed on the vehicle.

1. Remove the rear wheel. Refer to appropriate shop manual.
2. Remove and discard the shown screw and rivets.

FENDER FLARES KIT FOR CAN-AM RYKER

ZP-YJ-030610-012

SAUTV⁵

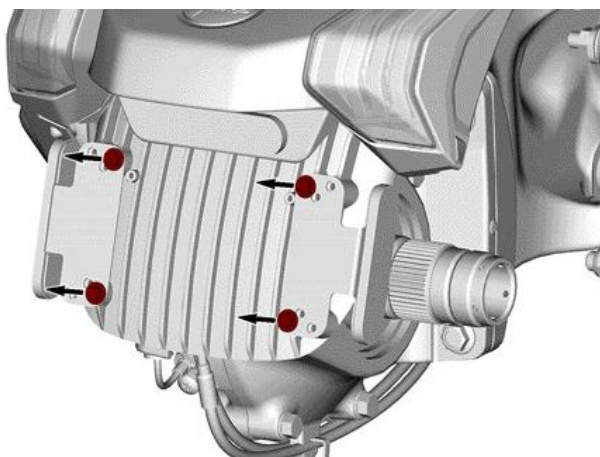

5. Remove and keep the two (2) reflectors.

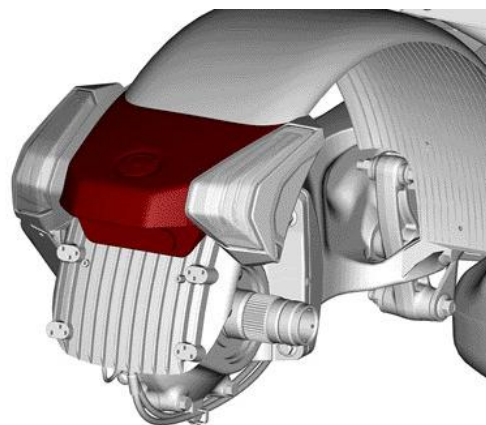

8. Remove and keep the two (2) shown screws.

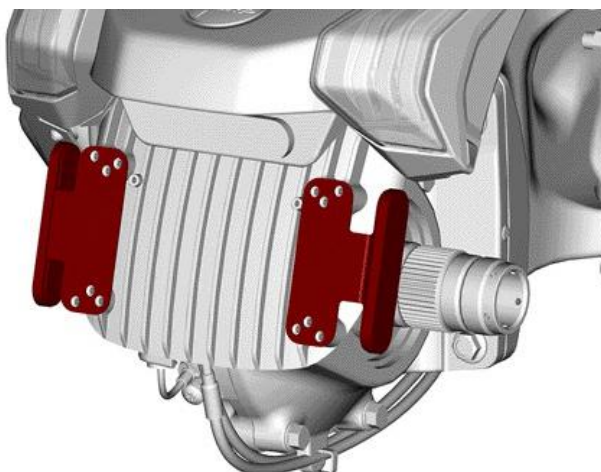

6. Remove and discard the screw retaining the rear fender trim.

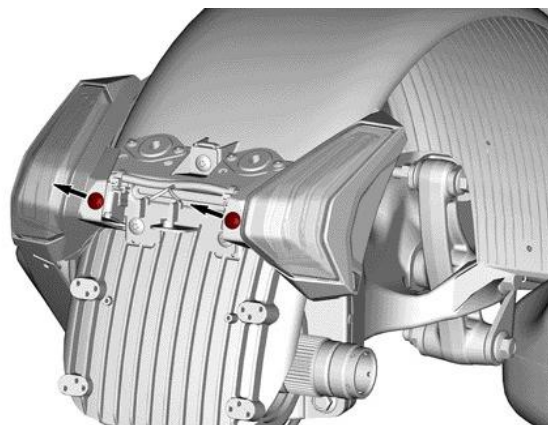

9. Remove and keep the LH and RH tail lights.

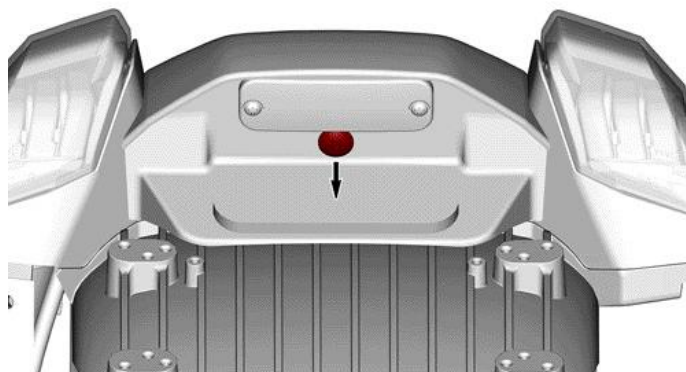

7. Remove and keep the rear fender trim.

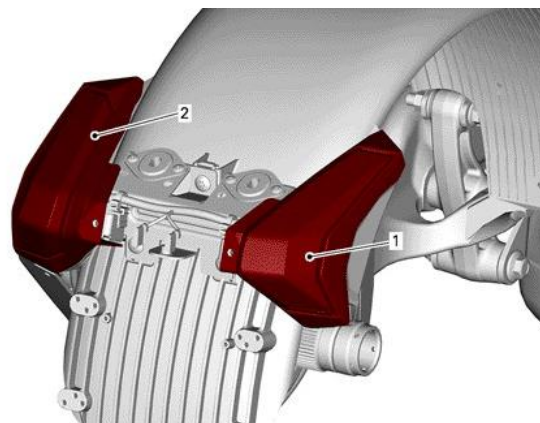

1. RH Tail light

2. LH Tail light

10. Remove and discard the three (3) shown screws.

FENDER FLARES KIT FOR CAN-AM RYKER

ZP-YJ-030610-012

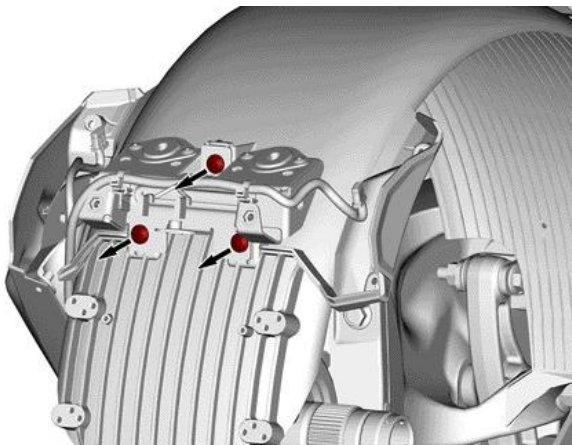

11. Remove and discard the rear fender by first removing the shown panel nut.

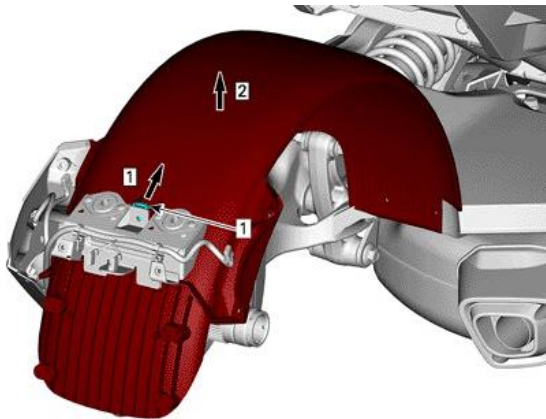

Panel nut

Part Installation

1. Install the mudguard [P3] on the vehicle using two (2) 3/16 black pop rivets [P6] and one (1) 8-32 screw [P5].

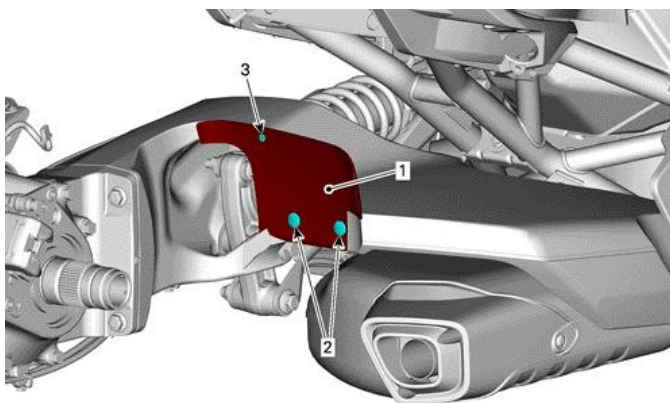

1. Mudguard [P3]
2. 3/16 Black pop rivets [P6]
3. 8-32 Screw [P5]

tightening torque	
8-32 Screw [P5]	3.5±.5N•m (31 ± 4 lbf•in)

2. Install the lower rear fender [P2] on the vehicle using three (3) M6X14 Torx screws [P10].

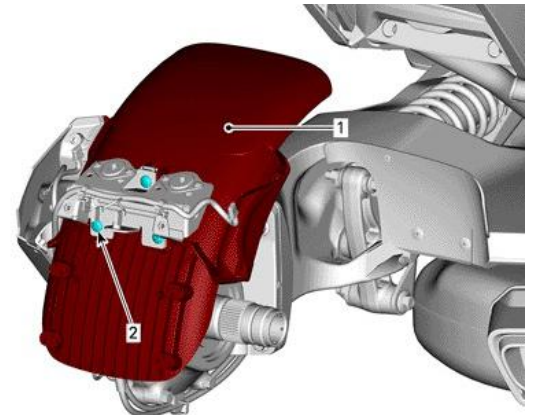

1. Lower rear fender [P2]
2. M6X14 Torx screw [P10]

tightening torque	
M6X14 Torx screw [P10]	5.5 ± .5 N•m (49 ± 4 lbf•in)

3. Reinstall the LH and RH tail lights on the vehicle, using the previously removed screws.

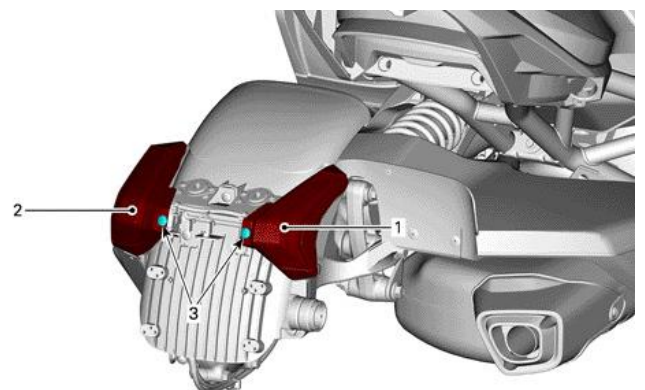

1. RH Tail light
2. LH Tail light
3. Previously removed screws

tightening torque	
-------------------	--

FENDER FLARES KIT FOR CAN-AM RYKER

ZP-YJ-030610-012



M6X14 Torx screw	5.5 ± .5 N•m (49 ± 4 lbf•in)
------------------	---------------------------------

4. Reinstall the rear fender trim using one (1) M6X14 Torx screw [P10].

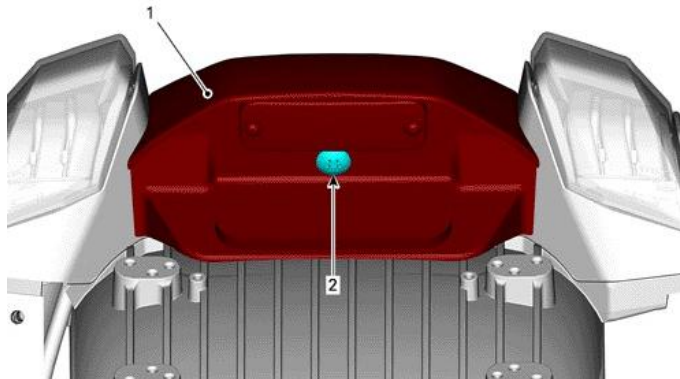

- 1. Rear fender trim
- 2. M6X14 Torx screw [P10]

tightening torque	
M6X14 Torx screw [P10]	5.5 ± .5 N•m (49 ± 4 lbf•in)

5. Screw the three (3) K40X12 Torx screws [P7] and the M5X16 Torx screw [P9] as shown.

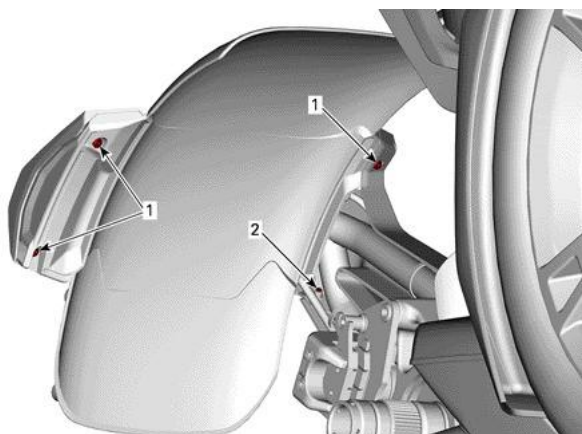

- 1. K40X12 Torx screws [P7]
- 2. M5X16 Torx screw [P9]

tightening torque	
K40X12 Torx screws [P7]	0.5 ± 0.15 N•m (4 ± 1 lbf•in)

M5X16 Torx screw [P9]	2.5 ± 0.5 N•m (22 ± 4 lbf•in)
-----------------------	-------------------------------

6. Reinstall the rear reflectors using four (4) M4X10 Plastite screws [P8].

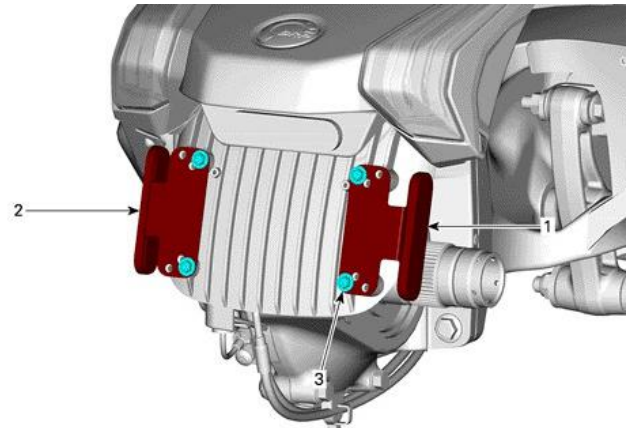

- 1. RH Reflector
- 2. LH Reflector
- 3. M4X10 Plastite screw [P8]

tightening torque	
M4X10 Plastite screw [P8]	1.5 ± 0.5 N•m (13 ± 4 lbf•in)

7. Install the upper rear fender [P1] using four (4) M6X10 Torx screws [P4].

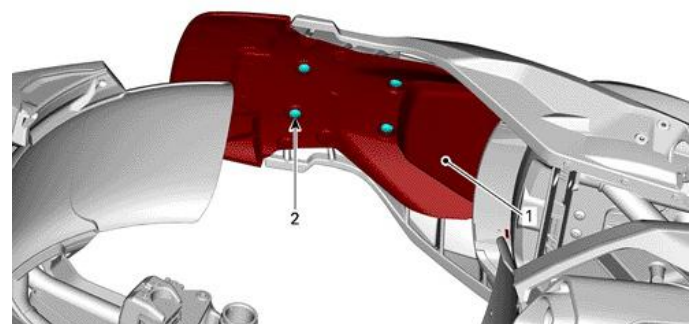

- 1. Upper rear fender [P1]
- 2. M6X10 Torx screw [P4]

8. Reinstall the rear wheel. Refer to appropriate shop manual.