

# Nerf Bars Rock Sliders for Can-Am Maverick X3 MAX

SAUTVS®

ZP-YJ-030606-008

## BEFORE YOU BEGIN

Read these instructions and check to be sure all parts and tools are accounted. Please retain these installation instructions for future reference.

## IMPORTANT

This NERF BARS ROCK SLIDERS KIT is exclusively designed for your vehicle. Please read the installation instructions thoroughly before beginning. Installation is easier if the vehicle is clean and free of debris.

## INSTALLATION INSTRUCTIONS

1. Shift vehicle transmission into "PARK". Turn key to "OFF" position and remove from vehicle.  
2. As shown in the figure, Parts 1, 2 and 3 are assembled by using 8 hex socket screws of M8\*50 and 8 lock nuts of M8 through 4 parts. The large hole of 4 parts is where the screws are screwed in during installation.



3. Use a 50 hole opener to open a 50mm hole at the position shown on the plastic parts on both sides of the car. The opening hole should be the same center as the hole reserved on the frame. If there is eccentricity, adjust the hole of the outer plastic parts with tools to ensure the correct position.

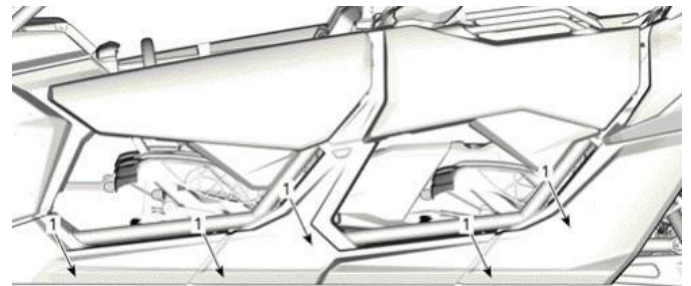

4. Inside the hole at the red circle position, the plastic ribs need to be cut with pointed-nose pliers to facilitate installation.



# Nerf Bars Rock Sliders for Can-Am Maverick X3 MAX

ZP-YJ-030606-008

SAUTVS®

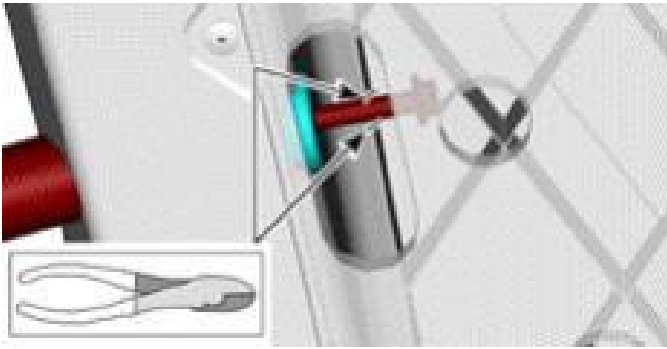

5. Install the side bar on the frame with 5 M10 \* 70 hex screws and 5 cast iron parts, as shown in the figure.

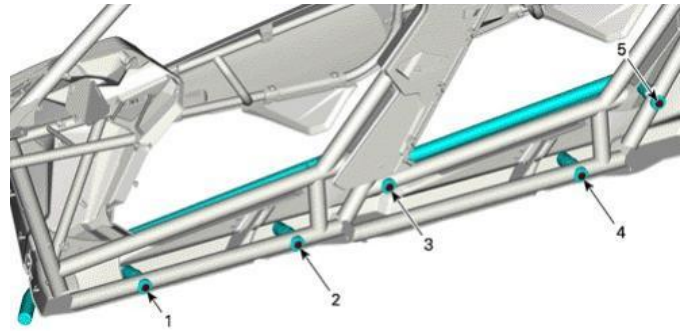

6. Tighten the M10 screws and then the M8 connection screws on the casing.

