

Rear Rack Mounting For POLARIS Sportsman 500

ZP-YJ-030503-120

BEFORE YOU BEGIN

Read these instructions and check to be sure all parts and tools are accounted. Please retain these installation instructions for future reference.

IMPORTANT

This Rear Rack Mounting is exclusively designed for your vehicle. Please read the installation instructions thoroughly before beginning. Installation is easier if the vehicle is clean and free of debris.

INSTALLATION INSTRUCTIONS

1. Shift vehicle transmission into "PARK". Turn key to "OFF" position and remove from vehicle.
2. Products and accessories:

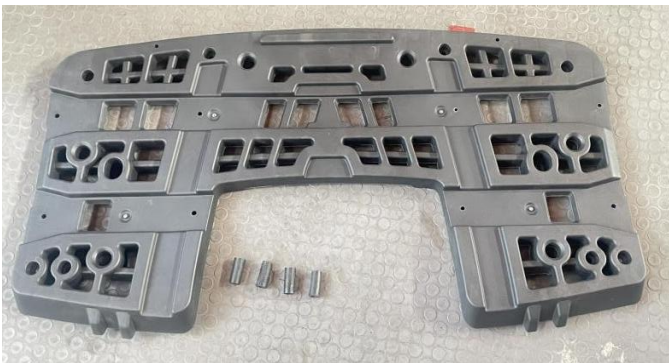

3. Remove the rear rack of the vehicle, and keep the original mounting screws, nuts and iron brackets. As shown below:



4. Fix the iron bracket (1 long and 2 short) of the original car on the rear rack, and then use the longest original screw to pass through the rear rack, put on the supporting liner, and then install the rack on the car (screws need to be stuck into the original fixing hole on the car),

and screw the nut on the bottom. As shown below:

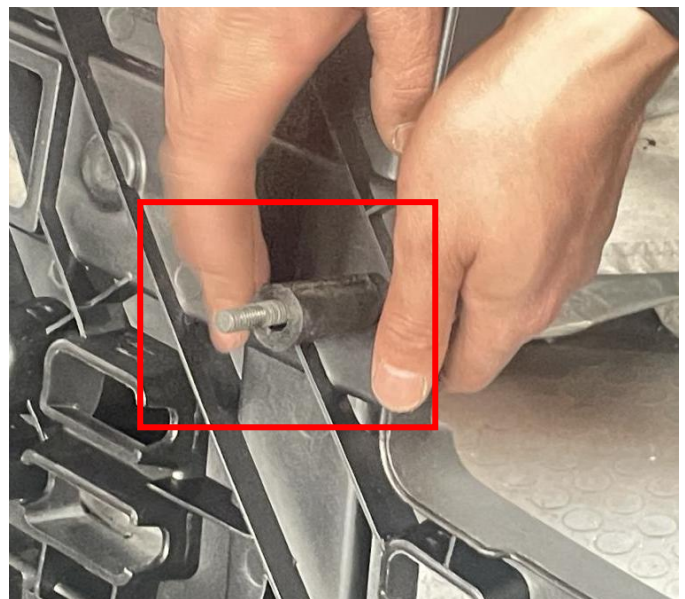
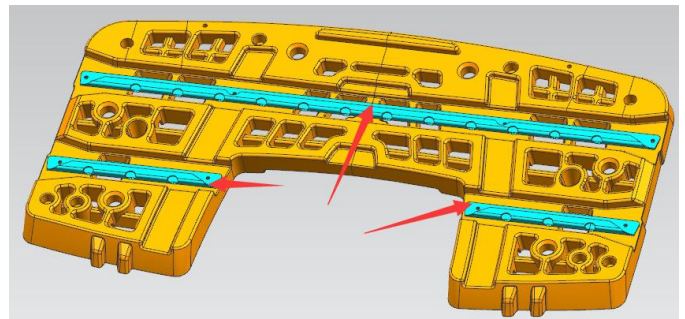

Rear Rack Mounting For POLARIS Sportsman 500

ZP-YJ-030503-120

shown below:

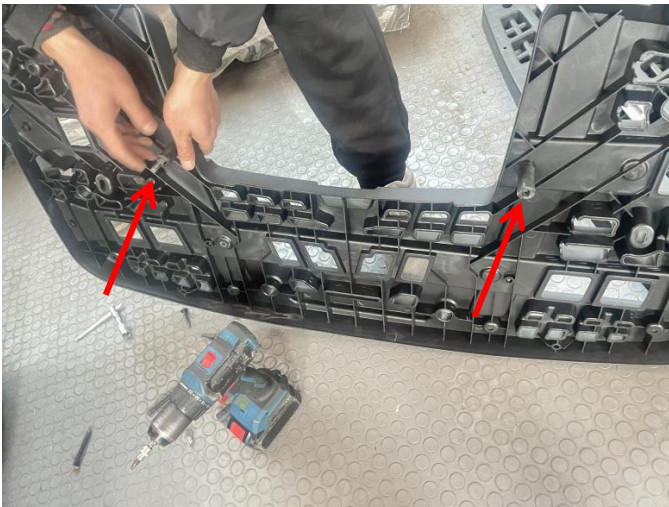

5. Prepare the original medium length screws, insert them into the fixing hole at the end of the rack, put the supporting liner over them and pass them through the fixing hole of the vehicle (both sides of the end need to be fixed in this way), and finally fix them with screws. As

Rear Rack Mounting For POLARIS Sportsman 500

ZP-YJ-030503-120

6. Use the shortest original screws to reinforce the remaining fixing holes in turn. As shown below:

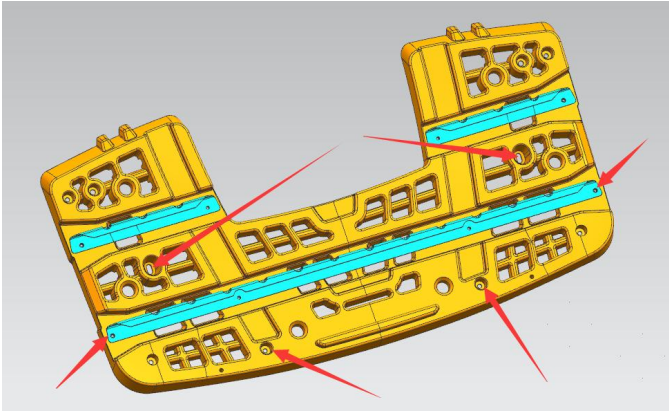

7. The installation completed.



Note: Please refer to the installation video in the Amazon listing before your installation, or contact the seller for the installation video.