

Front Bumper for Polaris RZR XP/XP4 1000 2024+



ZP-YJ-030506-039

BEFORE YOU BEGIN

Read these instructions and check to be sure all parts and tools are accounted for. Please retain these installation instructions for future reference.

IMPORTANT

This *Front Bumper Kit* is exclusively designed for your vehicle. Please read the installation instructions thoroughly before beginning. Installation is easier if the vehicle is clean and free of debris. For your safety, and to ensure a satisfactory installation, perform all installation steps correctly in the sequence shown.

INSTALLATION INSTRUCTIONS

Note: Shift vehicle transmission into "PARK". Turn key to "OFF" position and remove from vehicle.

Assembly

1. Assemble Part 1 and Part 2 by connecting tube A with 2pcs M8*50 hex screws and 2pcs M8 locknuts. Assemble Part 3 by connecting 2pcs tube B with 4pcs M8*45 hex screws and 4pcs M8 locknuts at the lower end. Assembly completed.

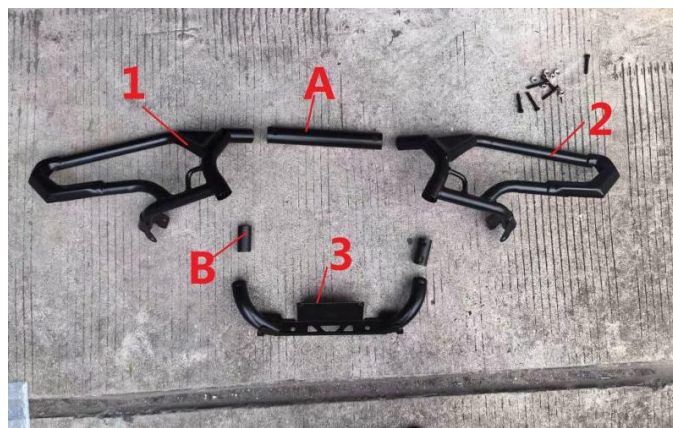

Assembled Front Bumper

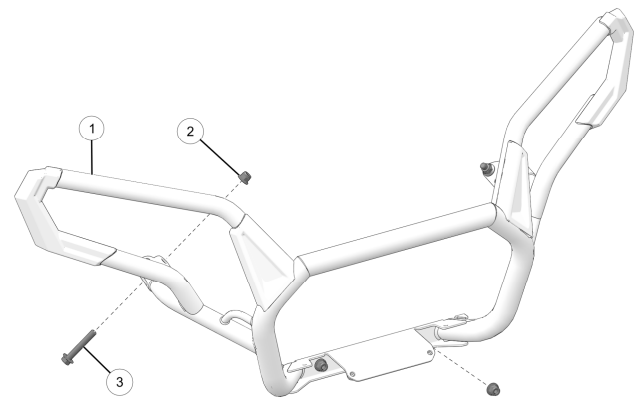

| Ref | Qty | Part Description |
|-----|-----|--|
| 1 | 1 | Bumper - Front |
| 2 | 4 | Nut - Hex Flange, Nylon Locking (M10 x 1.5 mm) |
| 3 | 2 | Screw - Hex Head Flange, (M10 x 1.5 x 65 mm) |

Grille Removal

1. Push two tabs down to remove grille.

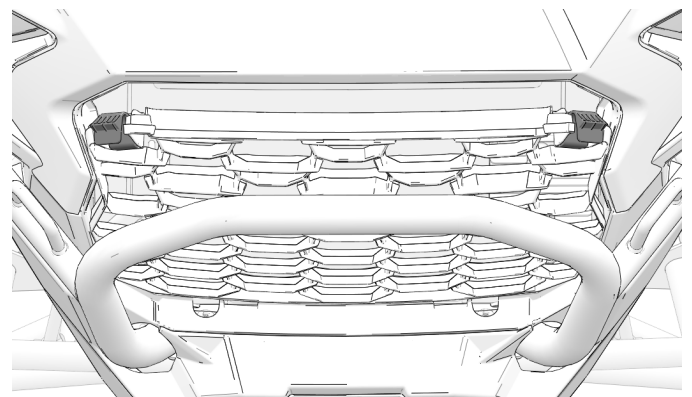

Front Bumper for Polaris RZR XP/XP4 1000 2024+



ZP-YJ-030506-039

Winch Cover Removal

1. Remove two upper winch cover fasteners.

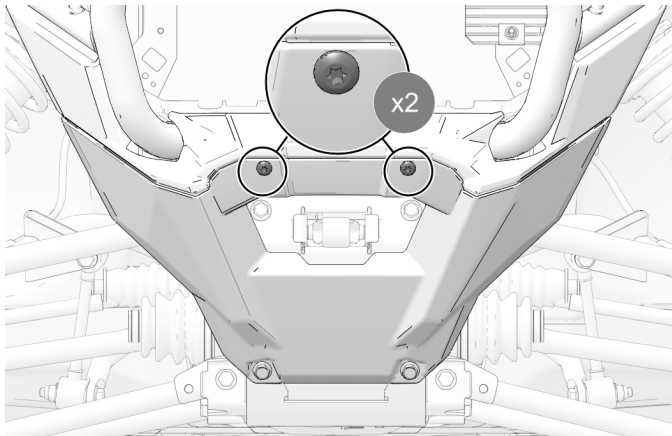

2. Remove two lower winch cover fasteners.

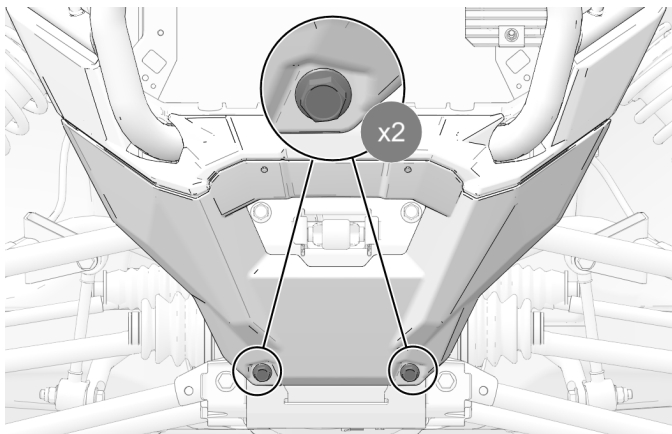

3. Remove winch cover from lower fascia.

TIP

Make sure tabs are disengaged from lower front fascia before pulling winch cover away.

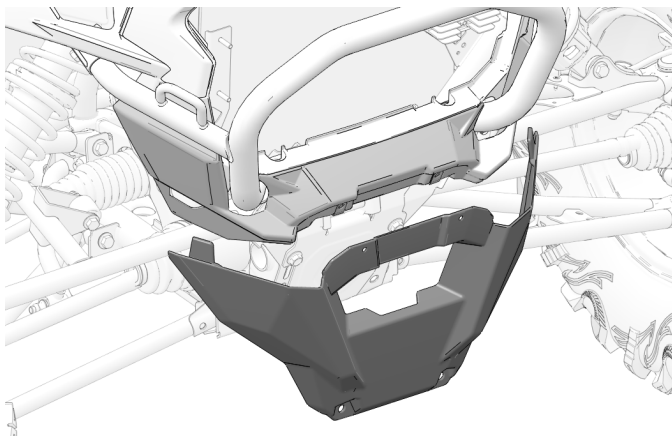

Lower Front Fascia Removal

1. Remove two lower fascia fasteners.

Notice:

One side shown; other side similar.

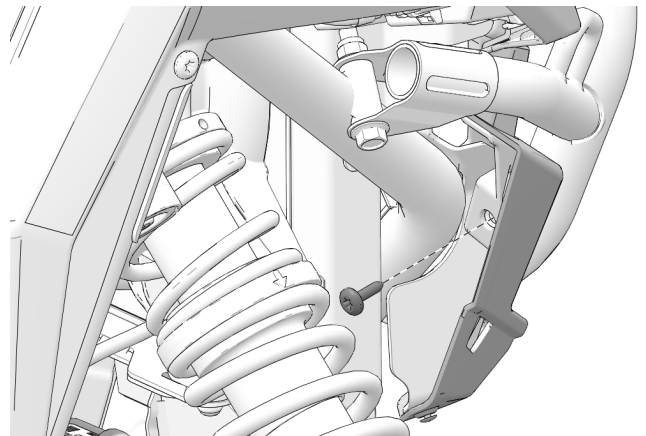

2. Remove one push-pin rivet from each side of front fascia.

Notice:

One side shown; other side similar.

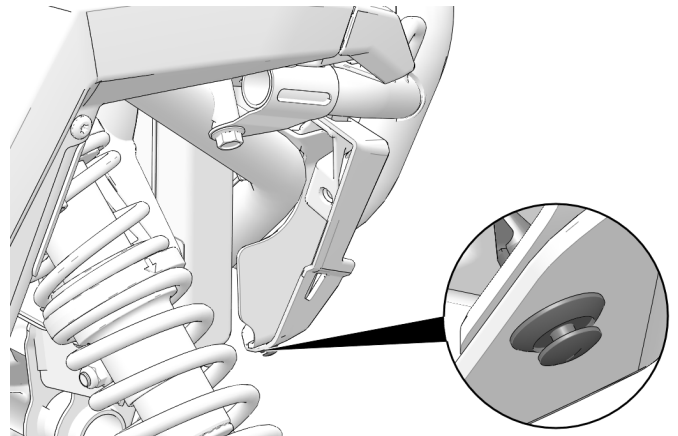

3. Remove two upper fascia fasteners.

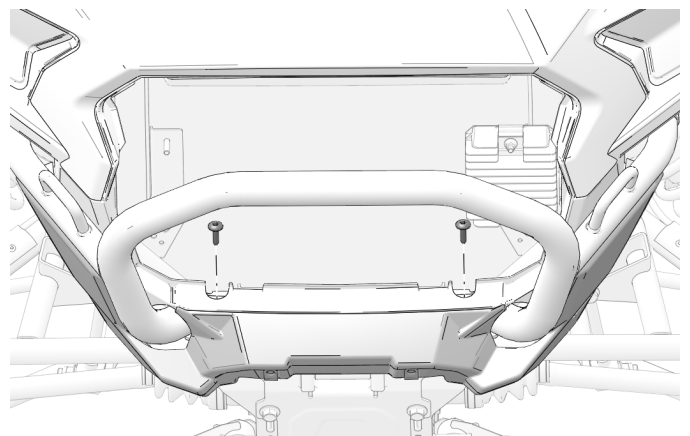

Front Bumper for Polaris RZR XP/XP4 1000 2024+



ZP-YJ-030506-039

Front Bumper Removal

1. Remove one nut and one fastener from each side of bumper.

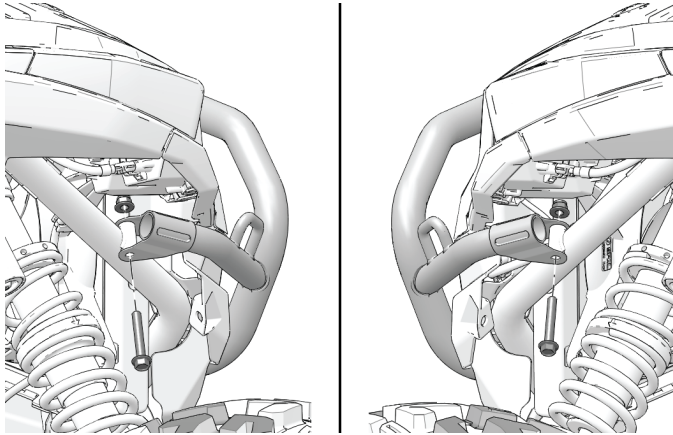

2. Remove two nuts from front of bumper.

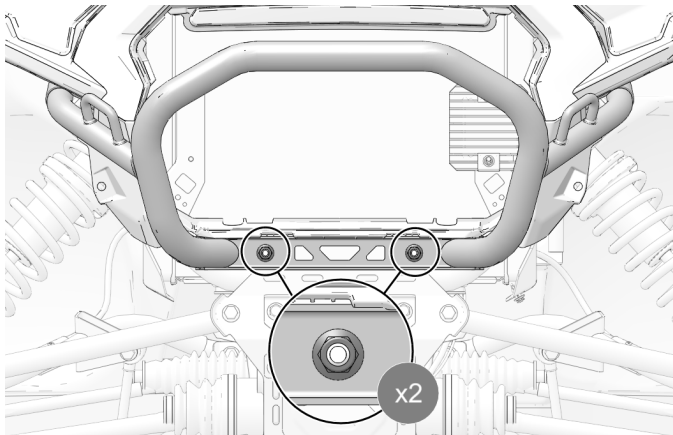

Accessory Installation

1. Align accessory bumper (1) with mounting points of stock bumper.

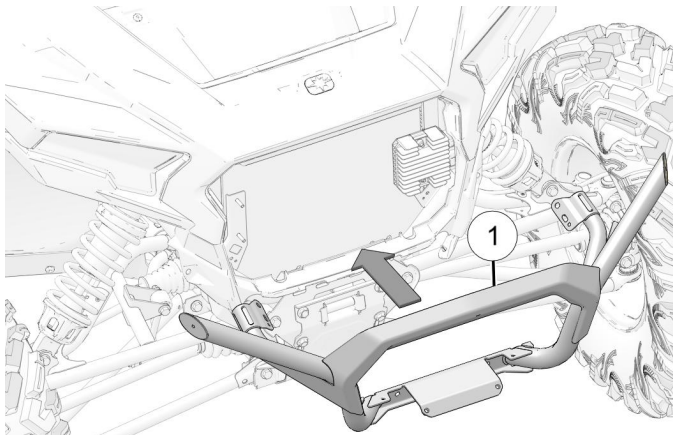

2. Loosely install front of bumper with two nuts (2).

Note: Do not torque nuts at this time.

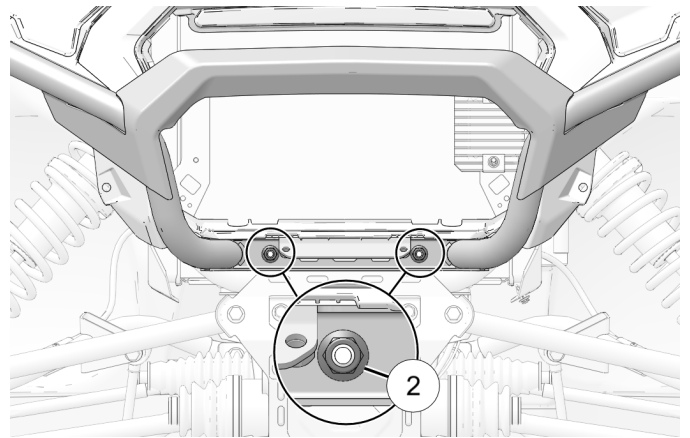

3. Install sides of front bumper with one nut (2) and one fastener (3) per side. Counter-hold nuts and torque fasteners to specification.

TORQUE

Front Bumper Fasteners (3) : 30 ft-lbs (40 N·m)

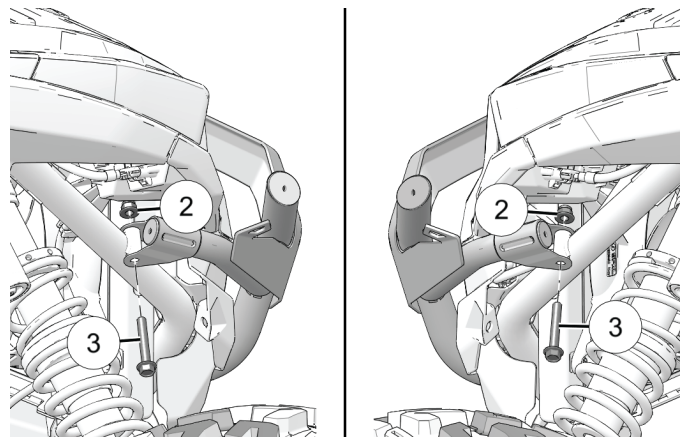

4. Torque two front nuts to specification.

TORQUE

Front Bumper Nuts (2) : 30 ft-lbs (40 N·m)

Vehicle Reassembly

Lower Front Fascia Installation

1. Install two upper fascia fasteners. Torque fasteners to specification.

TORQUE

Upper Fascia Fasteners: 70 in-lbs (8 N·m)

Front Bumper for Polaris RZR XP/XP4 1000 2024+



ZP-YJ-030506-039

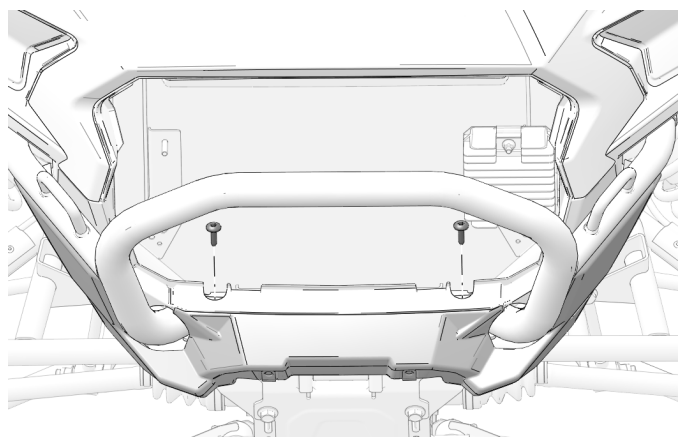

2. Install front fascia to radiator shroud with two push-pin rivets.

NOTICE

One side shown; other side similar.

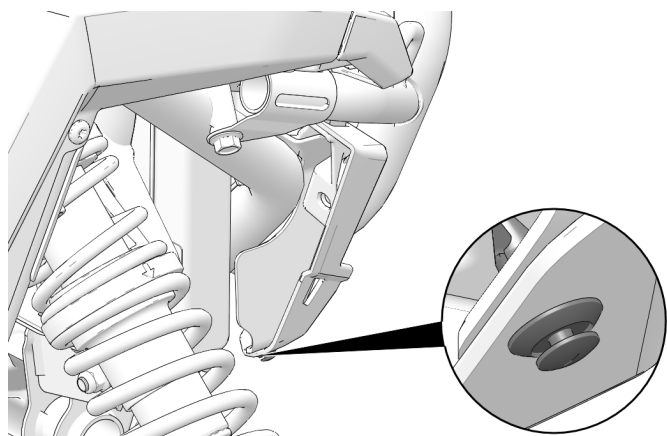

3. Install two upper fascia fasteners. Torque fasteners to specification.

NOTICE

One side shown; other side similar.

TORQUE

Lower Fascia Fasteners: 88 in-lbs (10 N • m)

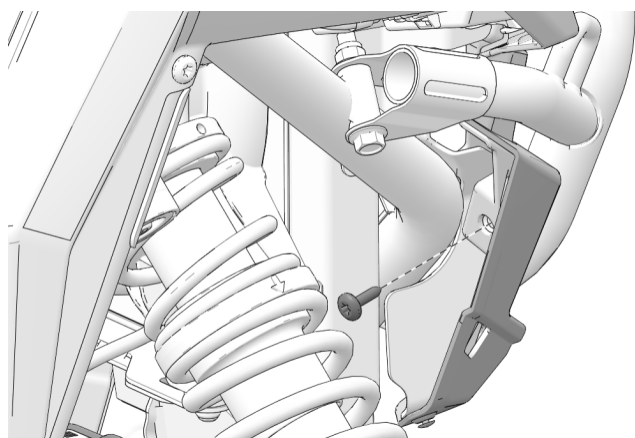

Winch Cover Installation

1. Align winch cover with lower front fascia. Make sure two tabs are inserted into fascia.

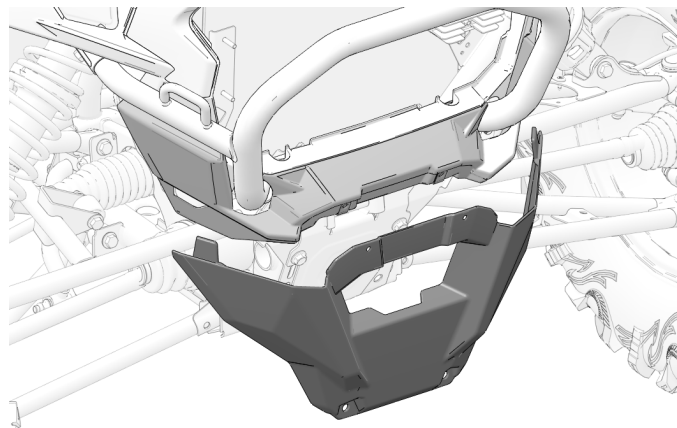

2. Install winch cover with two retained fasteners. Torque fasteners to specification.

TORQUE

Lower Winch Cover Fasteners: 88 in-lbs (10 N • m)

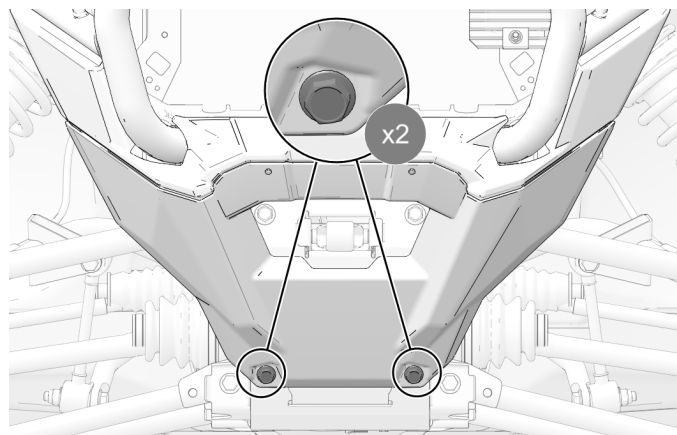

3. Install winch cover with two retained fasteners. Torque fasteners to specification.

TORQUE

Upper Winch Cover Fasteners: 88 in-lbs (10 N • m)

Front Bumper for Polaris RZR XP/XP4 1000 2024+



ZP-YJ-030506-039

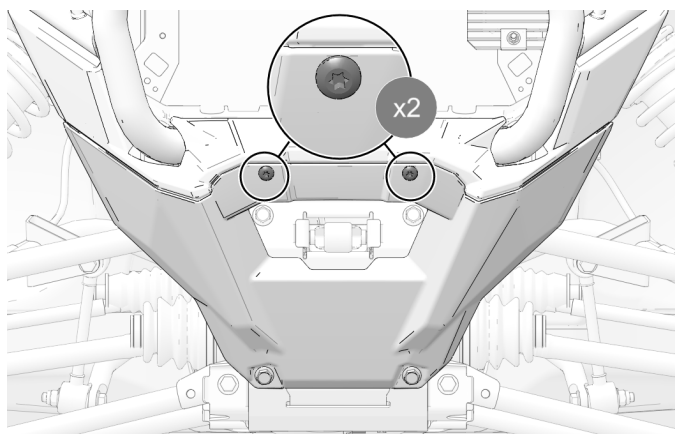

Grille Installation

1. Put bottom of grille in first and push top of grille in until two tabs engage upper front fascia.

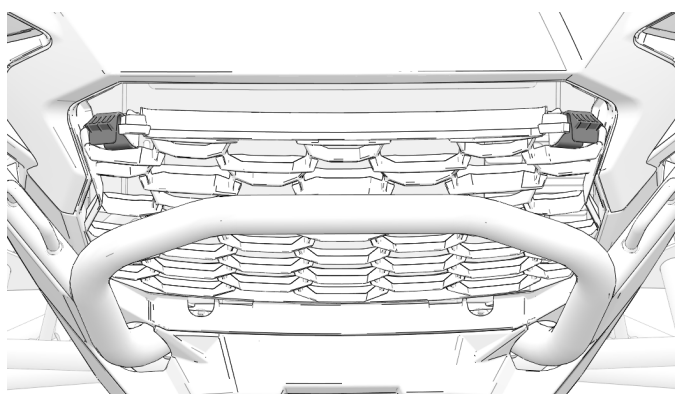

Installation finished.



Note: Please refer to the installation video in the Amazon listing before your installation, or contact the seller for the installation video.