

Rear Bumper for Polaris RZR XP/XP4 1000 2024+



ZP-YJ-030506-040

BEFORE YOU BEGIN

Read these instructions and check to be sure all parts and tools are accounted for. Please retain these installation instructions for future reference.

IMPORTANT

This *Rear Bumper Kit* is exclusively designed for your vehicle. Please read the installation instructions thoroughly before beginning. Installation is easier if the vehicle is clean and free of debris. For your safety, and to ensure a satisfactory installation, perform all installation steps correctly in the sequence shown.

INSTALLATION INSTRUCTIONS

Note: Shift vehicle transmission into "PARK". Turn key to "OFF" position and remove from vehicle.

Assembly

1. Connect Part L1 and Part 3 (Part R1 and Part 3) through Casing A by using four M8*50 hex screws and four M8 locknuts. Connect Parts L1 and L2 (R1 and R2) through Casing B by using four M8*55 hex screws and four M8 locknuts.

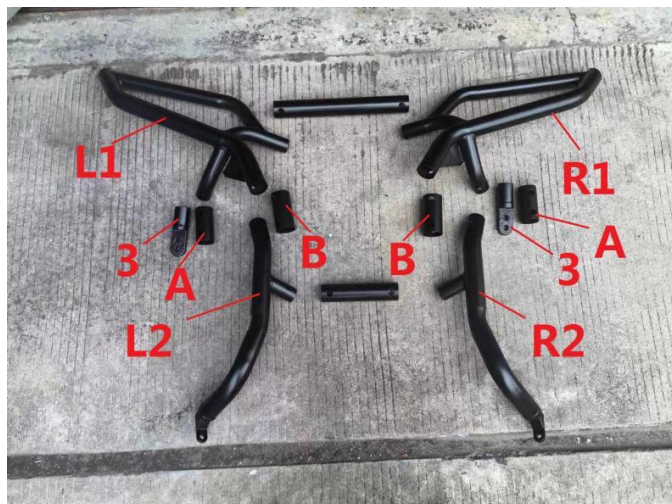

Note: The screw enters through the large hole in the casing.

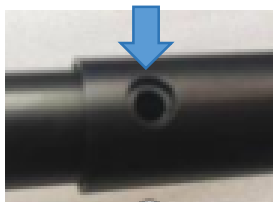

2. Assemble Part L and Part R through Casing

C and D by using four M8*50 hex screws and four M8 locknuts, as shown below:

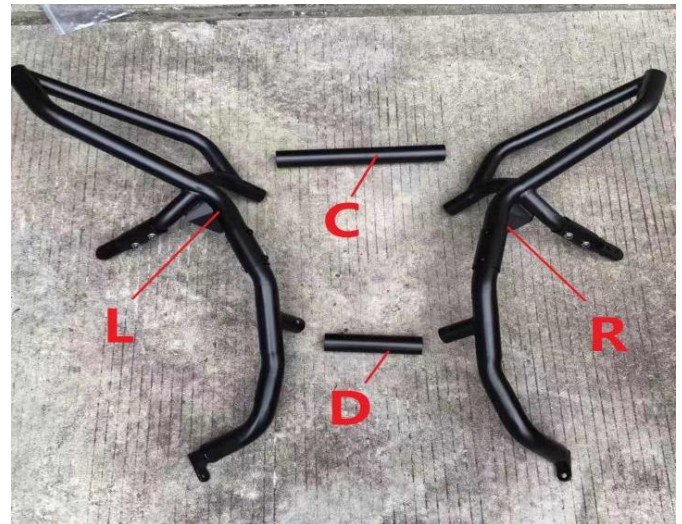

Rear Bumper for Polaris RZR XP/XP4 1000 2024+



ZP-YJ-030506-040

Installation

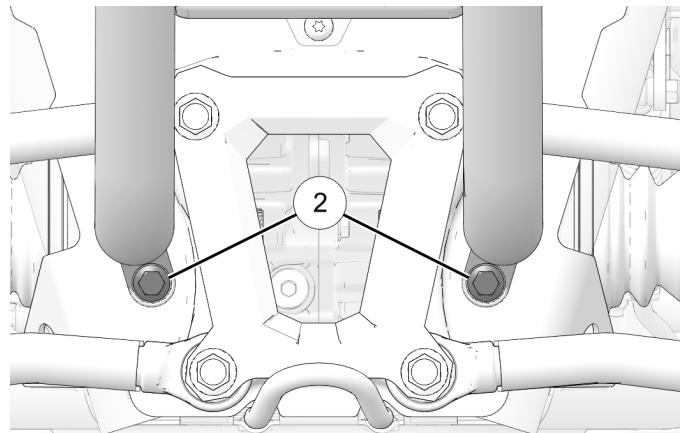
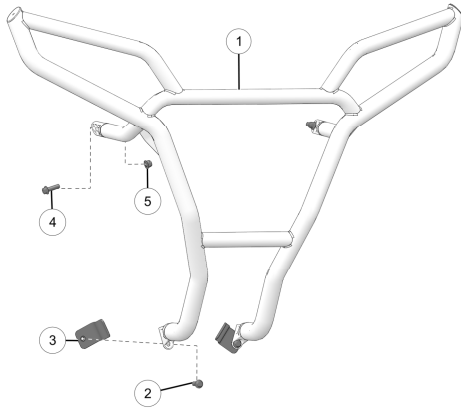

3. Put one bolt (4) through bumper and mount. Loosely bolt with one nut (5).

Note: Do not torque bolt at this time.

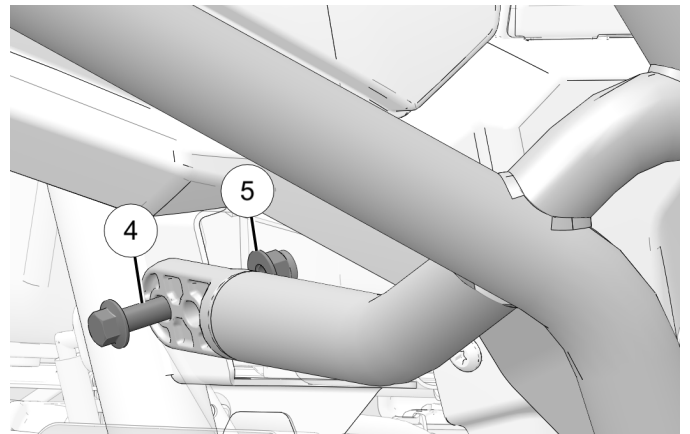

4. Put one bolt (4) through bumper and mount. Loosely install bolt with one nut (5).

Note: Do not torque bolt at this time.

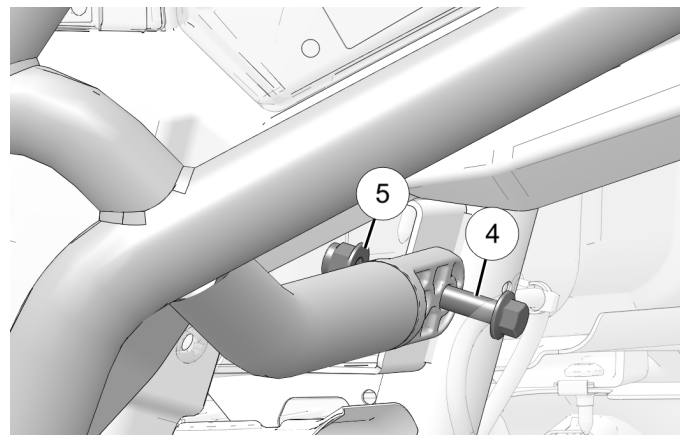

5. Loosely install two weld nut plates (3) to transmission bracket with previously installed bolts (2).

Ref	Qty	Part Description
1	1	Weld - Bumper, Rear
2	2	Screw - Hex Flange, Nylon Locking, (M10 x 1.5 x 35 mm)
3	2	Plate - Weld Nut, Bumper, Rear
4	2	Screw - Hex Flange, (M10 x 1.5 x 35 mm)
5	2	Nut - Nylon Locking, (M10 x 1.5 mm)

1. Align rear bumper (1) with transmission bracket and upper bumper mounts.

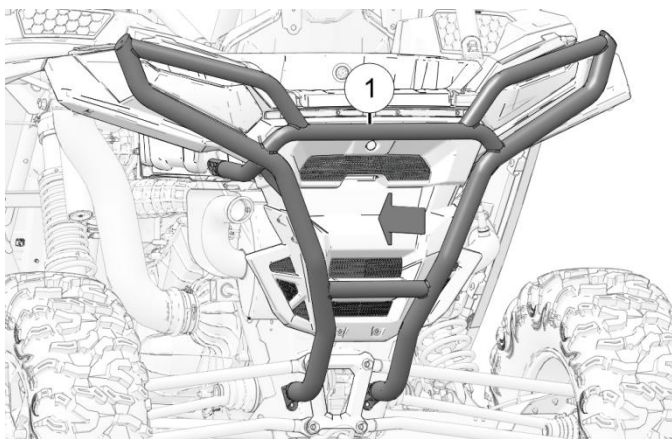

2. Put two bolts (2) through lower bumper mounts and through transmission bracket.

Rear Bumper for Polaris RZR XP/XP4 1000 2024+



ZP-YJ-030506-040

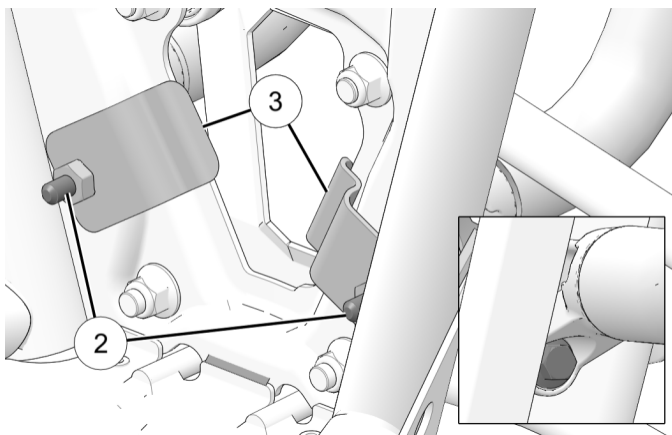

6. Hold weld plates in position and torque two bolts (2) to specification.

TORQUE

Lower Mounting Bolts (2) : 33 ft-lbs (45 N·m)

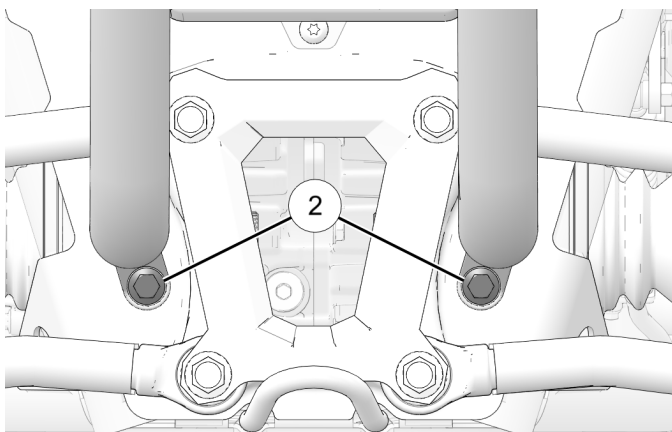

7. Counter-hold nuts (5) and torque upper mounting bolts (4) to specification.

NOTICE

One side shown; other side similar.

TORQUE

Upper Mounting Bolts (4) : 33 ft-lbs (45 N·m)

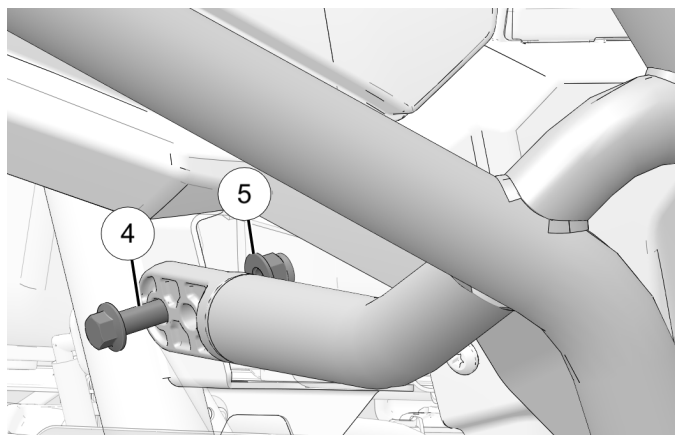

8. Installation finished.



Note: Please refer to the installation video in the Amazon listing before your installation, or contact the seller for the installation video.