

Front Bumper for Can-Am Maverick R

ZP-YJ-030606-019

SAUTVS®

BEFORE YOU BEGIN

Read these instructions and check to be sure all parts and tools are accounted. Please retain these installation instructions for future reference.

IMPORTANT

This FRONT BUMPER KIT is exclusively designed for your vehicle. Please read the installation instructions thoroughly before beginning. Installation is easier if the vehicle is clean and free of debris.

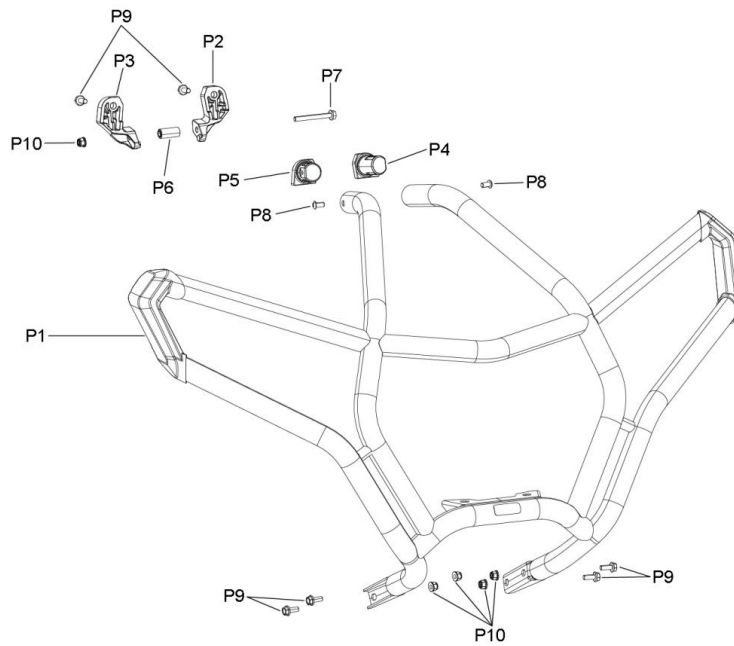

INSTALLATION INSTRUCTIONS

1. Shift vehicle transmission into "PARK". Turn key to "OFF" position and remove from vehicle.
2. Assembly of parts 1, 2, 3, 4L, 4R, 5, 6 through 8 sleeves (part 6) with 16 hexagon socket head cap screws of M8*50 and 16 locknuts of M8.



Front Bumper for Can-Am Maverick R

SAUTV5

ZP-YJ-030606-019

Note: Ensure that the holes for parts 4L and 4R are facing outward during installation.



3. Remove the hood by lifting the rear portion then sliding it forwards.

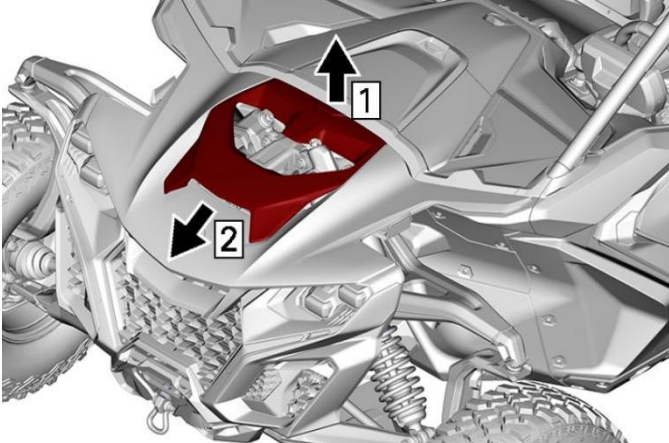

4. Insert LH and RH upper clamps [P4] and [P5] on bumper [P1] then secure using two M8 X 16 s.grip button head Torx screws [P8]. Do not tighten yet.

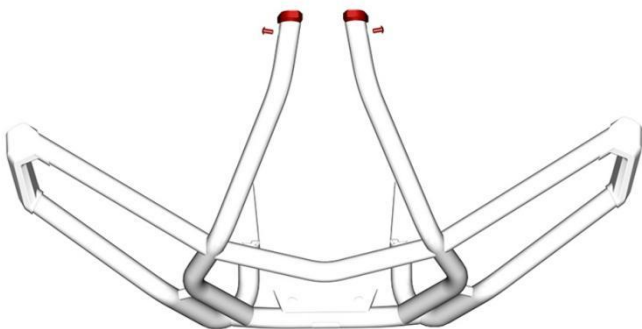

5. Locate the 2 holes in the chassis between the two front shock absorbers.

The larger hole is for inserting spacer [P6]. The locating protrusion is guided from the right side of the chassis (insert from the left side towards the right).

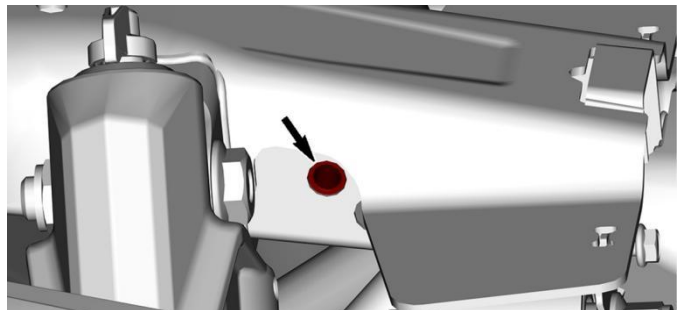
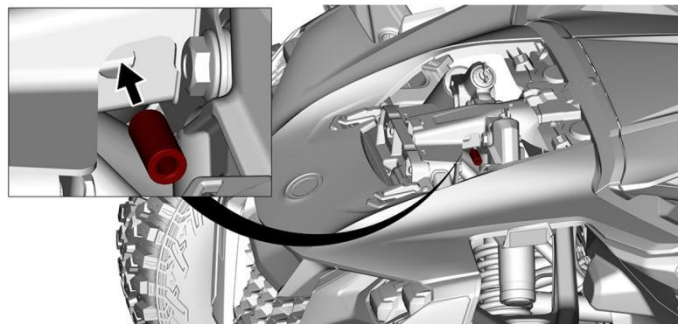
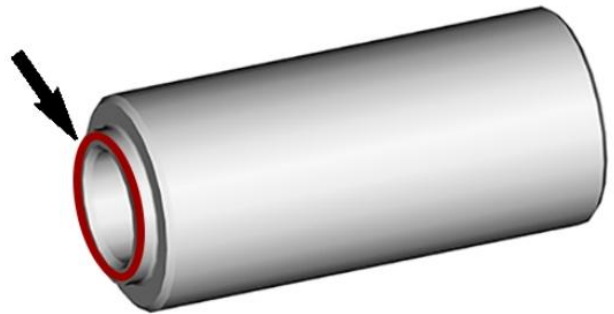
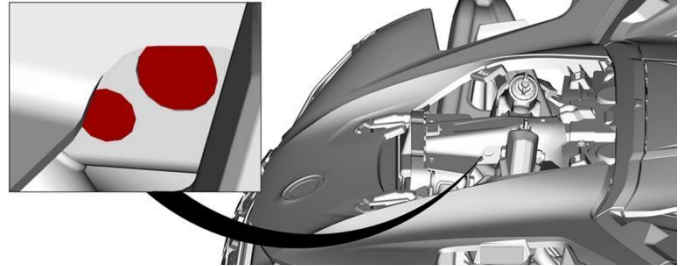

6. Take the two LH and RH lower clamps [P2] and [P3], the M8 X 70 hex. flanged screw [P7] and one M8 elastic flanged nut [P10]. The locating protrusion of the lower clamps fits into the small holes lower than the sleeve. Engage the screw with the nut on each side through the sleeve. Do not tighten yet.

Front Bumper for Can-Am Maverick R

ZP-YJ-030606-019

SAUTV5

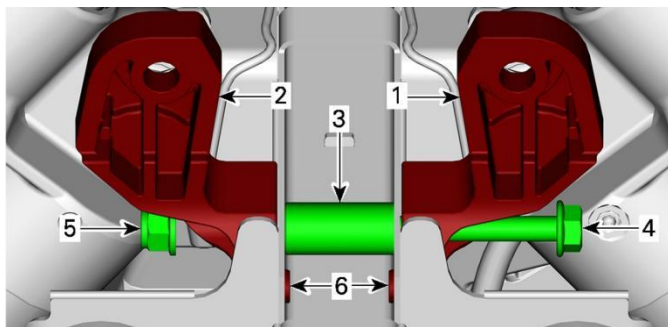
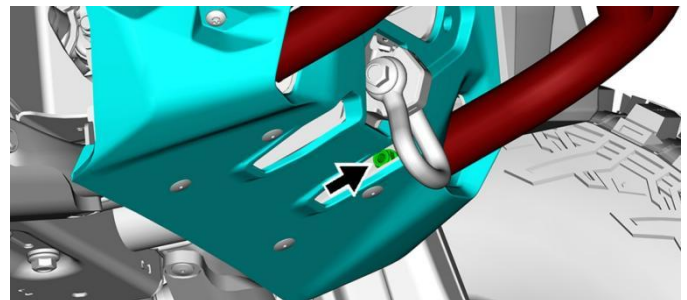
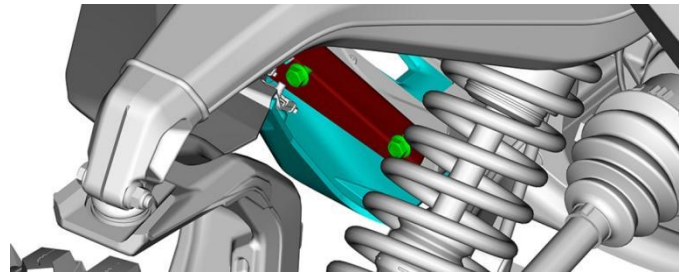
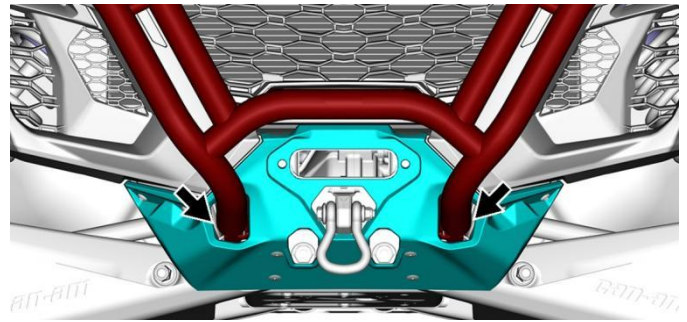
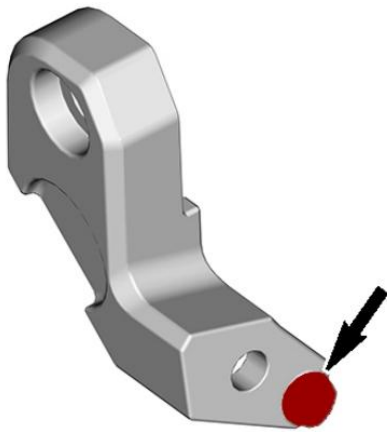

1. LH Lower Clamp [P2]
2. RH Lower Clamp [P3]
3. Spacer [P6]
4. M8 X 70 Hex. Flanged Screw [P7]
5. M8 Elastic Flanged Nut [P10]
6. Locating Protrusions of the Clamps

7. Reinstall hood on vehicle by sliding it rearwards and inserting the rear portion by pushing it down.

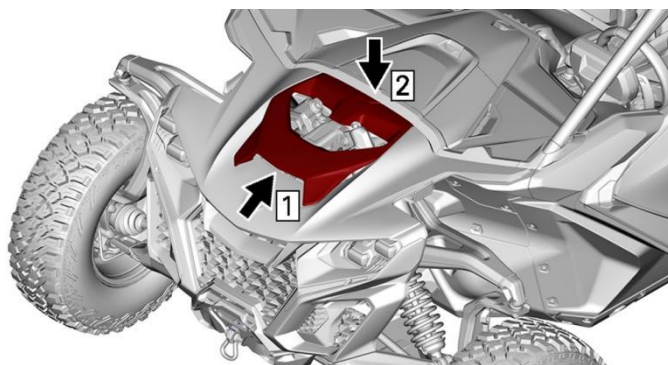

8. Insert the bottom of the bumper into the holes in the skid plate. Secure using four M8 X 20 s.grip hex. flanged screws [P9] and four M8 elastic flanged nuts [P10]. Insert screws from the sides and the rear nuts from the side. The front nuts through the skid plate holes. Do not tighten yet.

9. Secure the lower clamps to the bumper ass'y using two M8 X 20 s.grip hex. flanged screws [P9]. Do not tighten yet.

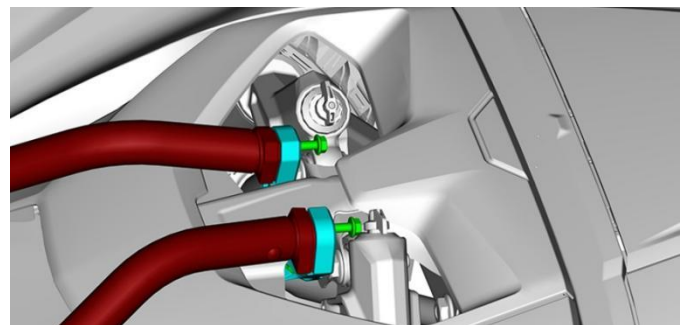

10. Tighten all screws and nut to specification.

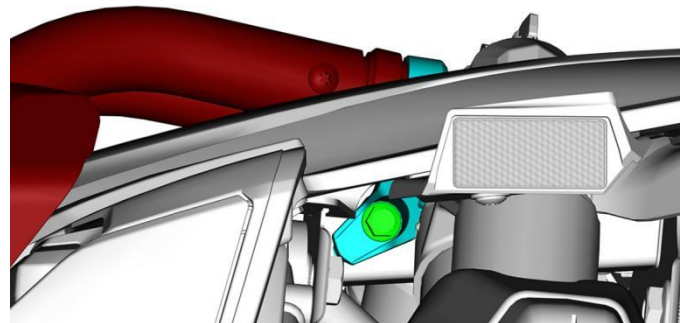

M8 X 70 Hex. Flanged Screw [P7]

Front Bumper for Can-Am Maverick R

ZP-YJ-030606-019

SAUTV5

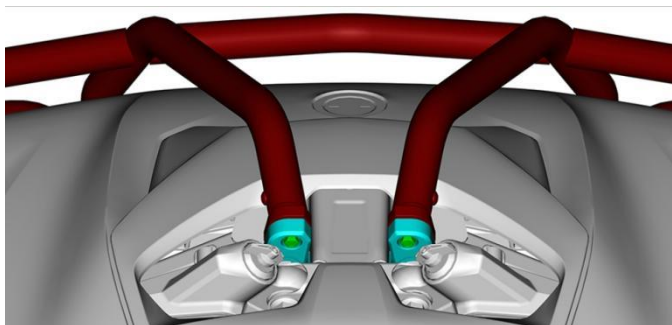

M8 X 20 S.Grip Hex. Flanged Screw [P9]

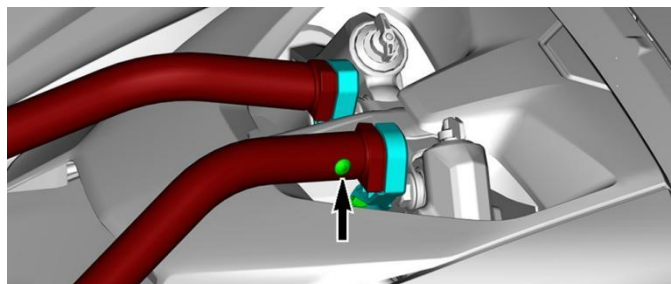

M8 X 16 S.Grip Button Head Torx Screw [P8]

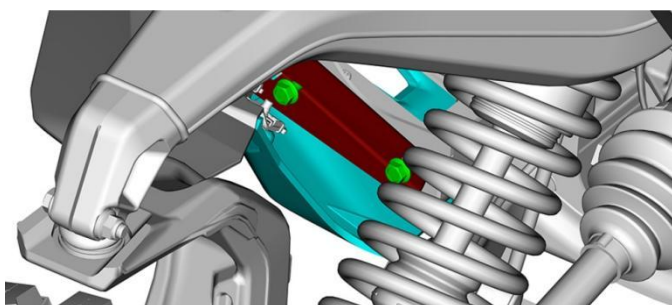

M8 X 20 S.Grip Hex. Flanged Screw [P9]

Note: Please refer to the installation video in the Amazon listing before your installation, or contact the seller for the installation video.